

UBC Social Ecological Economic Development Studies (SEEDS) Sustainability Program

Student Research Report

Redesign of 16th Avenue / SW Marine Drive Intersection Final Design Report

Prepared by:
Navroop Dhaliwal
Kimia Miraki
Dharmpreet Mundi
Kelvin Sarpong
Gurkirat Sital
Omar Soliman
Yuzhu Wang

University of British Columbia

CIVL 446

April 10, 2024

Disclaimer: "UBC SEEDS Sustainability Program provides students with the opportunity to share the findings of their studies, as well as their opinions, conclusions and recommendations with the UBC community. The reader should bear in mind that this is a student research project/report and is not an official document of UBC. Furthermore, readers should bear in mind that these reports may not reflect the current status of activities at UBC. We urge you to contact the research persons mentioned in a report or the SEEDS Sustainability Program representative about the current status of the subject matter of a project/report".

Executive Summary

The intersection of SW Marine Drive and 16th Avenue is a gateway that connects UBC to Vancouver. Currently, the intersection lacks critical environmental, efficiency, and safety measures in the form of erosion, space management, and speeding. The redesign of this intersection will focus on achieving the goals of creating additional green space, promoting active transportation, reducing vehicle speeds, and creating a visual gateway.

To achieve these goals, the design team focused on better utilizing the large site area and simplifying the intersection. The redesign of the intersection includes a 3-phase traffic signal that eliminates the need for slip lanes. This design creates plenty new green infrastructure, significantly lowers speeds, gives active transport users protection, and creates a informative gateway for the campus.

The project is expected to take 4 months to complete with construction starting on May 6th, 2024 and ending on September 4th, 2024. The overall cost of the project is estimated to be **\$4,235,560.00 CAD**.

TABLE OF CONTENTS

Executive Summary	1
1. Introduction.....	5
1.1 Background.....	5
1.2 Project Objectives	5
2. Site Overview.....	7
3. Project Objectives and Design Criteria.....	8
3.1 Primary Objectives.....	8
3.1.1 Other Design Criteria	9
3.2 Key Issues of the Intersection	9
3.4 Design Challenges	10
4. Summary of Design Elements	10
4.1 Traffic Flow System.....	11
4.2 Structural Gateway System.....	12
4.3 Stormwater Management System	13
4.3.1 Green Infrastructure Implementation.....	13
4.3.2 Utilities upgrades	15
5. Standards and Software Used	16
5. Technical Considerations and Rationale	19
5.1 Transportation Design.....	19
5.1.1 Existing Conditions.....	19
5.1.2 Geometric Design	21
5.2 Traffic Flow Analysis.....	26
5.3 Signage.....	27
5.4 Geotechnical analysis.....	28
5.5 Foundation and Bearing Capacity for Gateway Structure	28
5.6 Shear Bearing Capacity.....	28
5.7 Pavement Design	29
5.8 Structural Design	29
5.9 Foundation Design.....	30
5.10 Electrical Implementation.....	31
5.11 Hydrological analysis.....	31
5.11.1 Regional Rainwater Flow.....	32

5.11.2 Existing Conditions.....	33
5.12 Environmental Considerations.....	34
6. Schedule and Construction	35
6.1 Construction Requirements.....	35
6.2 Construction Phasing	35
6.3 Traffic Management Plan.....	36
7. Risk Assessment.....	37
8. Cost Estimate	39
9. Service Life Maintenance Plan	40
Conclusion	40
References.....	42
Appendix A: Supplementary Technical Information	44
Appendix B: Schedule Gantt Chart.....	50
Appendix C: Cost Estimate Details	51
Appendix D: Site Photographs.....	52
Appendix E: Roadway Maintenance Plan	54
Appendix F: Issued For Construction Design Drawings & Specifications	57
Appendix G: Codes Used.....	58
Appendix H: Gateway Lift Plan	59

List of Figures:

Figure 1: Site Location.....	7
Figure 2: Site Overview	8
Figure 3: 3D rendering of the proposed T-intersection design	11
Figure 4: Synchro Phasing Diagram	12
Figure 5: Phasing Diagram	12
Figure 6: Conceptual Rainwater Tree Trench system.....	14
Figure 7: OGS Stormceptor EF6 Model	15
Figure 8: Proposed location of OGS and detention tank	16
Figure 9: Conflict Points	20
Figure 10: Traffic Projections - now & 2075.....	27
Figure 11: Electrical Wiring Plan	31
Figure 12: 24-hour precipitation in 1:100 year storm event	32
Figure 13: Intensity-Duration-Frequency curves for Vancouver BC	33
Figure 14: Summary of Construction Schedule.....	36
Figure 15: Construction Phasing Map	37
Figure 16: Project Cost Breakdown.....	40
Figure 17: Member lengths and forces	44
Figure 18: Axial force analysis for each member	44
Figure 19: Shear force analysis for each member.....	45
Figure 20: Maximum moment on each member.....	45
Figure 21: Maximum displacement on each member.....	45
Figure 22: Site Photo 1 (March-27-2024).....	52
Figure 23: Site Photo 2 (March-27-2024).....	52
Figure 24: Site Photo 3 (March-27-2024).....	53
Figure 25: Site Photo 4 (March-27-2024).....	53

List of Tables:

Table 1: Member Contribution	6
Table 2: Design Tools used.....	17
Table 3: Design Standard and Guidelines used	17
Table 4: Summary of Roadway Lags.....	25
Table 5: 2075 Traffic Analysis	27
Table 6: Summary of Geotechnical Layers	28
Table 7: Sub catchments and their runoffs within the project area.....	34
Table 8: Temporary Sign Allocation [9].....	36
Table 9: Roadway Maintenance Plan [11].....	54
Table 10: From the BC MOTI Supplement (F1)	58
Table 11: From the BC Active Transportation Design Guide (F2)	58
Table 12: From TAC's Manual of Uniform Traffic Control Devices for Canada (F3).....	58
Table 13: From AASHTO's Policy on Geometric Design (F4)	58

1. Introduction

The intersection of SW Marine Drive and W 16th Avenue serves as a critical juncture, connecting the vibrant academic community of UBC Vancouver with the broader cityscape. The design team aims to transform this key junction to prioritize public transit and active-mode users, reduce vehicle speeds, and implement a new gateway structure along with green infrastructure.

1.1 Background

UBC's unique status as a quasi-municipal entity and its Campus and Community Planning (CCP) framework, places it in a distinctive position to take these challenges head-on. With UBC's population growing rapidly, the existing capacities for methods of transportation in the area are out-dated. The intersection's strategic significance is amplified by its role as a primary gateway to UBC from the wider Vancouver area. West 16th Ave is a major east-west thoroughfare, and one of the main routes connecting the UBC campus with the City of Vancouver. Thus, it serves as a vital transportation corridor for the university community and residents alike. Southwest Marine Drive is a major arterial road running primarily along the southwest edge of the city, from the UBC campus in the west to the Marpole neighborhood in South Vancouver. Likewise, SW Marine is also a significant access route linking the campus and the city. However, the existing design, characterized by its highway-oriented layout, presents numerous challenges- from pedestrian and cyclist safety to a lack of welcoming gateway to UBC. These issues not only impede the functional efficiency of the intersection but also detract from the sense of place that is crucial to the campus identity.

1.2 Project Objectives

The redesign project aims to redefine the intersection as a space that harmonizes with UBC's commitment to sustainability safety, and enhanced community connectivity. This comprehensive redesign effort is driven by the following key objectives:

- **Prioritize Public Transit and Active Modes:** Elevate the convenience and safety of public transit, walking, and cycling over single-occupant vehicle use.
- **Enhance Safety and Support for Non-motorized Transportation:** Design the intersection to safely accommodate, support, and attract individuals engaging in walking, and biking.

- Traffic Calming Measures: Implement design solutions that effectively reduce vehicle travel speeds, fostering a safer environment for all road users.
- Preservation of Natural Buffers: Maintain the existing green buffer zone adjacent to the UBC Botanical Garden, ensuring the protection of its ecological integrity.
- Integration of Green Infrastructure: Incorporate sustainable stormwater management practices to mitigate on-site water runoff and enhance the site’s resilience to climate change.
- Creation of a Visual Gateway: Develop a distinctive design feature that acts as a gateway to the UBC campus, offering a sense of arrival and welcome to visitors and the university community alike.

Table 1: Member Contribution

Team Member	Contribution
Navroop Dhaliwal	Executive Summary – Traffic Flow Analysis –Traffic Flow System - Site Overview - Appendix A
Kimia Miraki	Schedule and Construction – Construction Requirements – Construction Phasing – Risk Assessment – Cost Estimate – Service Life Maintenance Plan – Environmental Considerations – Structural Design – Appendix F – Appendix C
Dharmpreet Mundi	Gateway Drawing
Kelvin Sarpong	Design Criteria, Primary Objectives Key Issues, Design challenges, Geotechnical Analysis, Structural Design, Risk Assessment, Foundation and Bearing Capacity for Gateway Structure – Appendix A
Gurkirat Sital	Introduction, Hydrological Analysis, Review
Omar Soliman	Gateway Summary, Structural Design, Foundation, Electrical, Conclusion, Gateway lift plan – Appendix B
Yuzhu Wang	Transportation Design – Appendix F- Signage – Pavement Design – Site Overview, 3D Model and 2D Engineering Drawings

2. Site Overview

The project site is located at the intersection of SW Marine Drive and 16th Avenue. The site lies on the traditional, ancestral, and unceded territory of the Musqueam people.



Figure 1: Site Location

The site is mainly surrounded by green spaces including UBC’s Botanical Garden, Food and Physics Garden, and the Thunderbird stadium. The intersection currently at the site is complex and a high-speed environment. The arrows in Figure 1 below illustrate the flow of traffic as it passes through the intersection. This flow of traffic is unnecessarily complex and creates many conflict points. Furthermore, the diverging lanes for turns at the intersection occupy large areas and encourage drivers to speed through the site. Pedestrian pathways exist on the outskirts of the intersection; however, they lack a safe connection to the intersection making it challenging for active transport users to utilize the intersection.

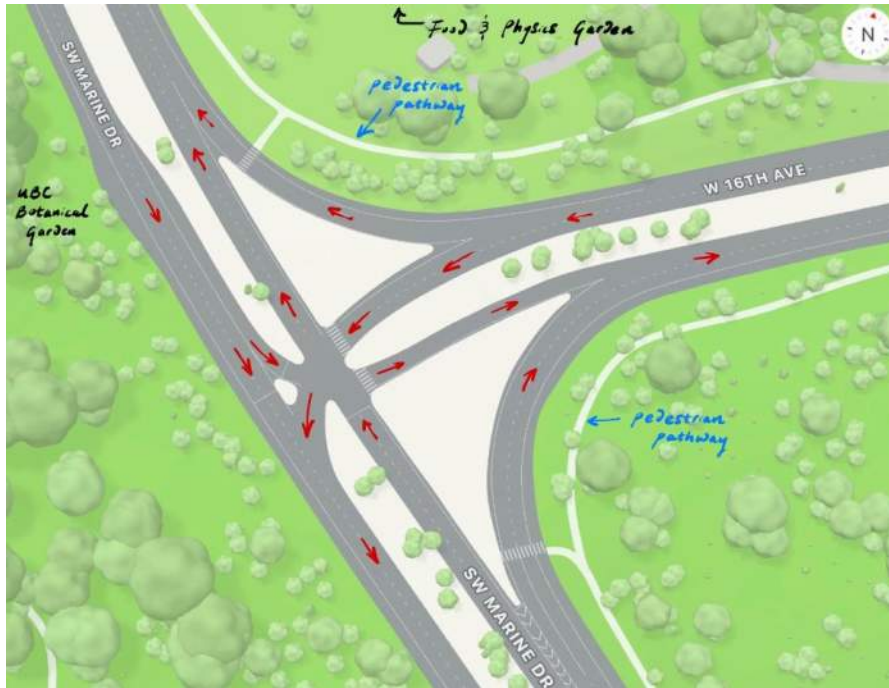

Figure 2: Site Overview

3. Project Objectives and Design Criteria

The various design criteria, key issues associated with the project, and the project constraints given by the client are explained below.

3.1 Primary Objectives

- Key consideration will be given to developing on site rainwater management system using green infrastructure. There is green infrastructure in the current design, but it must be redesigned to ensure rain-water runoff is properly directed.
- The use of public transportation and active transportation will be prioritized. Currently, there are no designated bike-lanes; only room on the shoulder of the road which cyclists could use.
- Automobile drivers must be encouraged to decrease speeds as they approach the UBC campus and neighboring areas.
- The project will emphasize accessibility and safety for pedestrians using sidewalks and crosswalks along SW Marine Drive and 16th Avenue.
- Maintaining a buffer zone with the nearby Botanical Gardens and between the project site.
- Implementation of a visual gateway to create a sense of arrival to the UBC campus.

3.1.1 Other Design Criteria

There are various design criteria which need to be satisfied within the redesign of the intersection. These include the design horizon, speeds, and vehicle types, which are summarized in the bullet points below:

- Service Life of 100 Years
- The redesign must be able to efficiently handle current and potential future traffic flows.
- Design Speed must be 50 kph for roads
- Design Speed must be 20 kph for the MUP
- Design must accommodate all travel modes

3.2 Key Issues of the Intersection

In the process of redesigning the intersection, and taking into consideration the most significant impediments imposed by the current structure of the roadway, the following problems were highlighted as the key issues such as, Lack of pedestrian and cyclist safety, Green infrastructure and rainwater detention, Speeding and No sense of arrival onto UBC campus.

Pedestrian and cyclist safety: The current intersection design fails to provide adequate infrastructure for ensuring the safety of pedestrians and cyclists. This includes sub-optimal bike lanes, a lack of sidewalks, pedestrian signals, and dedicated pathways for bikers and rollers. Moreover, the legal speed limit of 80 km/hr after the intersection presents a substantial safety concern, dissuading active transport users. Commuters and pedestrians often experience discomfort due to the proximity of high-speed vehicles and the inadequately designed crosswalks.

Green infrastructure and rainwater detention: The current rainwater detention infrastructure at the intersection is incapable of effectively handling all the stormwater on site. This leads to erosion along the roadway slopes during periods of excessive rainfall. Aligning with the client's commitment to sustainable development and minimizing tree loss, a primary focus of the redesign will be integrating green infrastructure to enhance stormwater capture capabilities.

Speeding: The highway-style layout of the roadway leading to the intersection from Marine Drive poses a significant safety hazard. Often perceived as a high-speed highway rather than a road appropriate for an urban setting, such as a large university campus and residential neighborhood, this section consistently experiences excessive speeding. The prevalent high speeds not only endanger pedestrians but also pose risks to other motorists, resulting in a history of accidents, with vehicles frequently exceeding 90 km/hr. Redesigning this section is crucial to establish a safer and more suitable traffic environment for all users, including pedestrians, cyclists, and motorists.

No sense of arrival into UBC campus: The current design of the roadway near the UBC campus lacks clarity in signaling the transition from the surrounding city to the campus area, leading to a lack of awareness among drivers. This ambiguity contributes to speeding issues near the campus, as drivers may inadvertently maintain high speeds close to the university environment. Addressing this issue is pivotal for enhancing safety and awareness within the densely populated university area.

3.4 Design Challenges

Limited access to underground services: Restricted access to underground services posed a significant challenge, as strict regulations prohibited any alteration to the existing infrastructure. This restriction notably impacted the hydrotechnical and geotechnical aspects of our redesign efforts, limiting our options for rainwater management and hindering modifications to drainage systems. To navigate these constraints, innovative design approaches were necessary to ensure compliance with regulations while effectively addressing design criteria and resolving key issues.

Lack of as-built drawings: The absence of as-built drawings for the current intersection design added another layer of complexity to our process. Without detailed documentation, the team had to rely on assumptions about the site's conditions, introducing uncertainty regarding the precise layout of the intersection. This reliance on inferred information underscored the importance of accurate documentation for future projects.

4. Summary of Design Elements

The choice of design is a signalized T-intersection at SW Marine Drive and West 16th Avenue. Figure 3 below is from a 3-dimensional rendering of the model generated using the Autodesk InfraWorks software, adhering to the project requirements and design criteria. The design features a structural gateway spanning across SW Marine Drive, with an LED board powered by 4 solar to provide a sense of arrival onto the UBC campus. To prioritize active modes of transport, Bike lanes have been placed on SW Marine Drive, and pedestrian zebra crossings are on every side of the intersection to ensure pedestrian safety. Additionally, to effectively manage stormwater flow, a catch basin and detention tank will be utilised to ensure effective rainwater detention.



Figure 3: 3D rendering of the proposed T-intersection design

4.1 Traffic Flow System

The traffic flow at the intersection will be managed by a 3-way semi-actuated uncoordinated traffic light system. The system will run a 3-phase signal as illustrated in the phasing diagram below. The first phase will permit southbound traffic to pass the intersection on SW Marine drive and turn left onto 16th avenue. This phase will also permit a right turn from 16th avenue onto SW Marine Drive. After the southbound left turn signal turns red the next phase will begin which will permit both northbound and southbound traffic to go through the intersection. During this phase there will be no right turn allowed to accommodate any active transport users wanting to cross 16th avenue. The last phase will allow 16th avenue drivers to turn left onto SW Marine drive while also permitting northbound drivers to turn right onto

16th avenue. This phase will not permit a right turn for westbound drivers onto SW Marine drive to accommodate cyclists wanting to cross SW Marine drive.

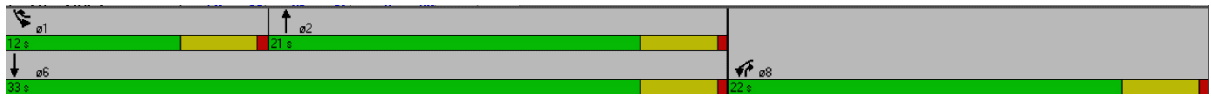

Figure 4: Synchro Phasing Diagram

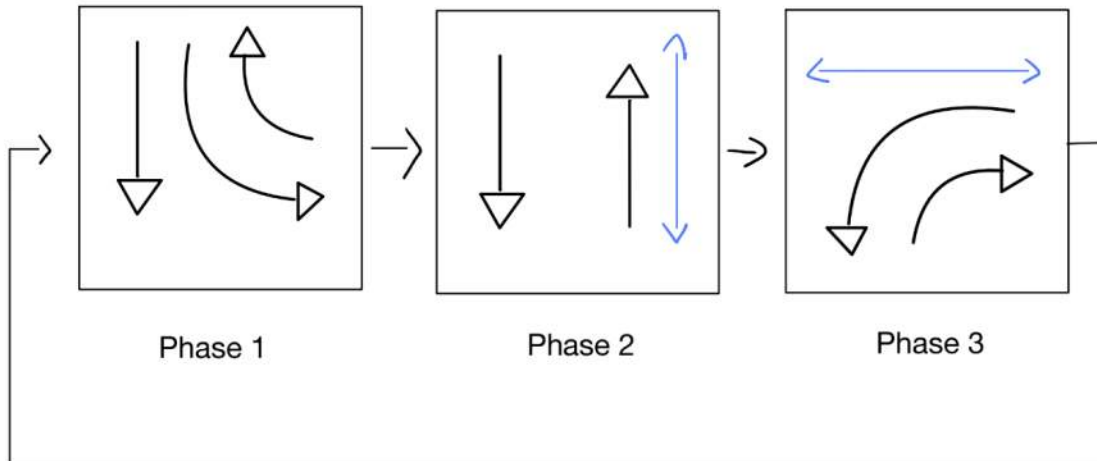

Figure 5: Phasing Diagram

In the phasing diagram above, the black lines represent the vehicle traffic direction during each phase. The blue lines in phases 2 and 3 indicate when and where active transport users will be able to navigate the intersection. Overall, the traffic flow system will provide active transport users with a safe and simple way to navigate the intersection while also reducing the speed of approaching vehicles.

4.2 Structural Gateway System

The design incorporates a structural digital gateway system to instill a sense of arrival to UBC for northbound traffic on Southwest Marine Drive. The system contains Hollow Structural Steel (HSS) and with a digital sign to show a variety of message to roadway users. The system is equipped with four 30-watt Monocrystalline Solar Panel Kits (AX30), ensuring a renewable energy cycle and adhering to UBC’s sustainability action plans. A comprehensive 3D model illustrating the Gateway system can be seen in Appendix 4. The location coordinates are 49°15’04’’N and 123°14’42’’W.

4.3 Stormwater Management System

This section will describe the stormwater management system which is a mixture of Low Impact Development strategies and an upgrade to the existing infrastructure.

4.3.1 Green Infrastructure Implementation

Stormwater retention strategies are focused on managing pervious runoff by utilizing green infrastructure to facilitate groundwater infiltration and evapotranspiration. Calculations for impervious runoffs reveal that approximately 40% of the rainwater reaches the pervious areas. As the predicted precipitation will seep into the pervious areas of the sub catchments, it is crucial to incorporate green infrastructure to treat and manage the stormwater. Our Low Impact Development (LID) approach includes the integration of bioswales and rain gardens into the design to allow water to percolate through the soil, naturally filtering pollutants and recharging groundwater reserves. The rain gardens will promote water to infiltrate directly into the ground below and will be linked to a tree trench system, directing any overflows to the new utilities. As learned from the UBC HydroGeo study provided, the precipitation that falls on the Point Grey Peninsula that the UBC campus sits on seeps into the ground is heavily significant for the healthy tree growth within the area as well as seep into the underlying Quadra Sand unit leading into the Upper Aquifer.

Bioswales along the sides of SW Marine Drive and W 16th Avenue will mimic the natural processes of soil and vegetation to manage stormwater. The captured stormwater from both impervious and pervious surfaces will be filtered as they pass the bioswales, therefore improving the quality of water which will then be conveyed to a rain garden set up for stormwater management. Rainwater tree trenches are to be used to redirect the collected rainwater from the street to the rain gardens. The infiltration into the soil along with the bioswales will clean the rainwater runoff and reduce the amount of water entering the sewers. An ideal schematic of the tree trench for rainwater use is shown in the figure below. These measures have already been implemented throughout the City of Vancouver in areas such as Richards Street as well as Yukon & 63rd Street and its implementation in the high-density areas has shown promise in treating water quality issues as well as flood prevention.

CONCEPTUAL RAINWATER TREE TRENCH

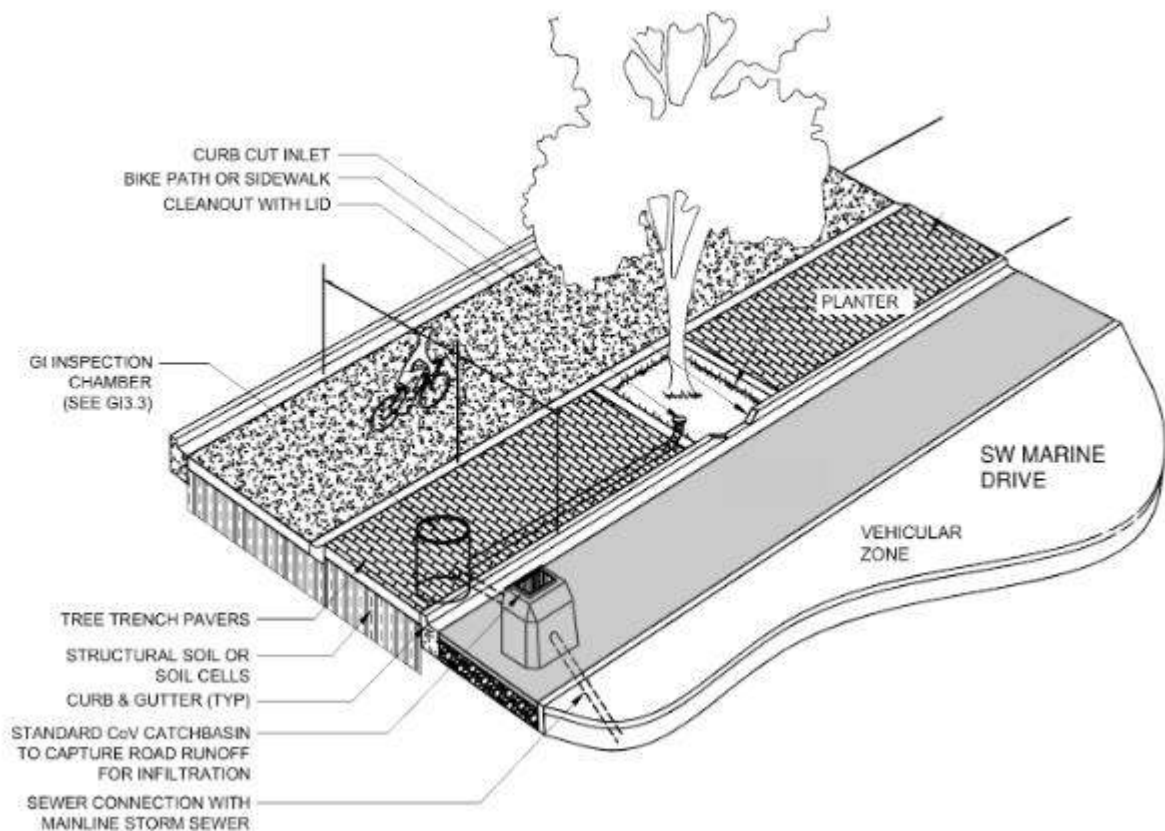

Figure 6: Conceptual Rainwater Tree Trench system

Trees planted in median islands as well as in the rain garden will not only enhance the urban aesthetic but also serve a vital function in flood prevention and stormwater management. Their root systems act as natural detention areas, absorbing excess water and reducing runoff volumes. It is suggested that Western Red trees be used for the rain garden running along the sides of the roads as already present and Red Maple trees be introduced in the median for the sense of aesthetics as well as capturing rainwater. The preferred design for these options is shown in the new intersection design drawings. This retention approach not only mitigates the immediate impacts of storm events but also contributes to the long-term resilience of the urban ecosystem against extreme weather patterns. The soil depth of the rain garden is designed to be 150mm with 200mm of bedrock layer underneath. Clean out drains are to be used around the existing utilities on both sides of the W 16th Avenue linking the rain gardens to the catch basins. 40-50% of the soil should be clay with 30% sand and the remaining organics to be placed in the rain garden. A sandy clay soil with these characteristics will not only help emulate the vegetation in these rain gardens but also control the infiltration of stormwater into the ground, promoting more retention. The rain gardens would include

naturally occurring vegetation and tufted hairgrass along with the Western Red trees for stormwater management.

4.3.2 Utilities upgrades

In designing this system, a key emphasis was placed on the containment and treatment of contaminants. Originating from various urban activities, pollutants require sophisticated management strategies such as Oil/Grit Separators (OGS) and sedimentation filters to ensure they do not compromise water quality. The OGS, as depicted in the provided schematic below, is a Stormceptor EF6 model designed with chambers to trap sediment and separate oil, efficiently removing contaminants before the stormwater is eventually released to the detention tank. This multi-stage treatment is critical for protecting downstream water bodies and maintaining the integrity of municipal water systems. Beginning with stormwater detention: new constructed impervious runoff, volume calculation, design itself- includes an emphasis on contaminants, sources and the need for OGS and sedimentation filters as well as treatments within the baffle tank.

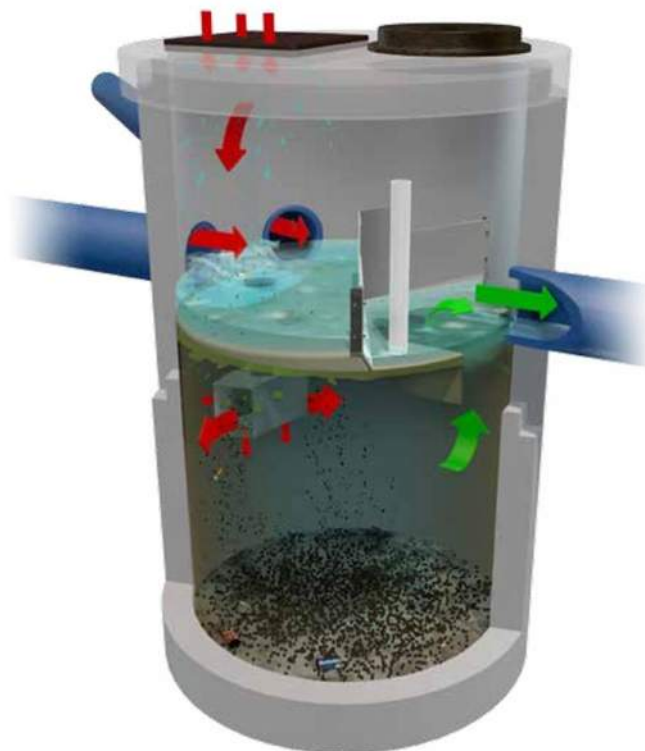

Figure 7: OGS Stormceptor EF6 Model

With the inclusion of an OGS in the system, a detention tank of 24m x 12m x 3m will be placed downstream of the OGS on the East side of SB Marine Drive- with 120 linear meters

of 800mm HDPE pipe connecting the OGS and the detention tank to the existing utilities. To make the project cost-effective another option was considered of the design of a baffle tank which includes multiple chambers for sedimentation, treatment and finally storage. The design offers a serpentine flow path, increasing the retention time of the stormwater within the tank and enhances sedimentation. For the baffle tank design, an additional volume factor of 40% was assumed to account for the sedimentation and treatment zones making the tank 24m x 12m x 3m. The location of the OGS and Detention tank are shown in the image below.

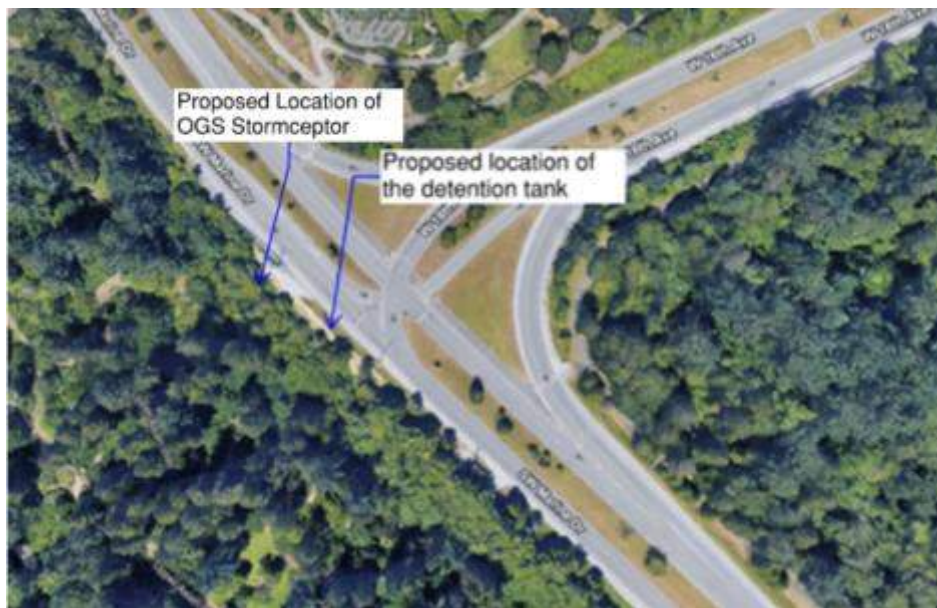

Figure 8: Proposed location of OGS and detention tank

Although cost effective, the bigger size of the tank poses complications with the nearby area due to being close to a cliff. To prevent erosion and the impact of the bigger tank on the trees in the limited area, a separate OGS and detention tank is preferred. The water is to be collected by catch basins along SW Marine Drive and 16th Avenue. The catch basins have been strategically placed on all sides of the intersection which are tied into the existing stormwater mains. A schematic of these catch basins is provided in the Appendix A below. The HDPE pipe connecting these catch basins will lead downstream to the OGS and then finally to the detention tank which links to the UBC Botanical Garden outfall.

5. Standards and Software Used

The Standards and software utilized for the design of intersection are summarized in table 2 and 3.

Table 2: Design Tools used

Design Tool	Purpose
Autodesk InfraWorks	CAD software used in creating 3D models of the conceptual, preliminary, and detailed designs for the intersection. High-quality renderings were made to communicate design concepts more effectively in presentation to the client.
Autodesk Civil 3D	Civil 3D was used to create horizontal alignments, profiles, cross-sections, and other engineering drawings of the design with precision. This program includes corridor modeling capabilities, incorporating grades, superelevation, and vertical curves to accommodate changes in terrain.
Synchro	Traffic simulation software tool used for traffic signal optimization and intersection analysis. Synchro provides tools for analyzing operational characteristics (including capacity, level of service, delays), and for optimizing the timing and phasing of traffic signals at intersections to improve traffic flow.
S-Frame	S-Frame was used to undertake a structural analysis of the gateway to ensure structural stability. It provided an analysis for the axial forces, midspan deflections, shear forces, support reaction forces and moments for all members of the structure.
EPASWMM	EPASWMM was used to analyze the current stormwater utilities and estimate the peak runoff volumes from a 1:100 year storm event. It provided the discharge rates, flooding areas, sub-catchments and runoff volumes from those sub-catchments.

Table 3: Design Standard and Guidelines used

Design Standard and Guidelines	Purpose
TAC Geometric Design Guide for Canadian Roads (2019)	Roadway Geometric Specifications
BC MOTI Supplement to TAC (2019)	Roadway Geometric Specifications
AASHTO Policy on Geometric Design of Highways and Streets (2019)	Roadway Geometric Specifications

BC Active Transportation Design Guide (2019)	Roadway Geometric Specifications
BC MOTI Project Cost Estimating Guidelines	Cost Estimation
2020 Standard Specifications for Highway Construction Volume 1 and 2	Cost Estimation and Scheduling
Guide to Cost Predictability in Construction	Cost Estimation
Environmental Best Practices for Highway Maintenance Activities	Environmental Considerations
Budget Guidelines for Consulting Engineering Services	Cost Estimation
BC MOTI Construction Sign Guide	Traffic Management Plan
BC Wildlife Tree Committee Mandate	Environmental Considerations
2018-19 BC MOTI Maintenance Specification	Service Life and Maintenance Plan

5. Technical Considerations and Rationale

5.1 Transportation Design

To further describe the transportation design of this project, existing conditions, geometric design and signage placement have been emphasized.

5.1.1 Existing Conditions

Underpinned by the importance of West 16th and SW Marine Drive as major access routes between the city and the university campus, the layout of the intersection prioritizes and reduces delays for passenger cars and motorized vehicles. This presents challenges for the integration of active transportation infrastructure, as the imbalance in prioritization leads to safety issues for active mode users, perpetuating dependence on cars. On the east approach of the intersection, West 16th carries two lanes of vehicle traffic in each direction, including shoulders beside the right lanes. The east and west directional traffic are separated by a grassed median, that is approximately 10 meters wide. There is a slip lane for vehicles turning right from West 16th onto SW Marine. Towards the south, there is another slip carrying two lanes of right turning traffic from SW Marine onto the eastbound of West 16th. These lanes have very large radii, which were likely designed to facilitate smoother and more gradual turns for vehicles, allowing them to maintain higher speeds while making the turn.

On the south approach of the intersection, the northbound direction carries two lanes of through traffic, in addition to two dedicated right turn lanes (as previously described). Two lanes of traffic turn left from West 16th onto the southbound lanes of SW Marine. On the north approach of the intersection, the slip lane (for right turning vehicles from West 16th) joins with two lanes of through traffic that crossed the intersection. However, this additional third lane does not require vehicles to merge into the adjacent left lane, as it leads to a lane for right turning vehicles at the intersection with Stadium Road (an access road to the Thunderbird Stadium). In the southbound direction, there are two lanes of through traffic in addition to one dedicated left turn lane. Similar to West 16th, a shoulder lane is present on the right side of vehicle traffic lanes, and the directional traffic is separated by a grassed median (of 10 meters).

The separation of different directional lanes at the intersection, the presence of multiple traffic signals, and the high number of lanes creates many conflict points. These points are

locations where the paths of different vehicles or pedestrians intersect, creating potential opportunities for conflicts or collisions. There are at least nine total conflict points at the intersection (for merging, diverging, and crossing conflicts), and they have been identified in the annotated illustration below. At the center of the junction, (separate) traffic signal lights were installed for each direction lane (4 total). This may create confusion for auto drivers and pedestrians crossing the intersection.



Figure 9: Conflict Points

There is very limited infrastructure to support active-mode users. Presently, there are no biking facilities at the intersection, such as bicycle lanes or bike-on-shoulder lanes. However, it is generally unsafe for cyclists to travel on the shoulder lanes, as speeding is a major concern (with some vehicles travelling up to 80 km/h). It is anticipated that cyclists should use the narrow pathways (displayed in yellow color in Figure 9) on the east side of the intersection. There are no sidewalks on the west side, adjacent to the southbound lanes of SW Marine. There is a segment of pedestrian sidewalks beside the northbound lanes, at the center of the junction. For the user to travel from the north to the

h pathway (and vice versa), the user must cross four roadways. As shown in the figure, the length of the crossing (in orange color) is also very long, increasing exposure to traffic and prolonging the time spent in the roadway. Moreover, two of these four crossings are uncontrolled, meaning that they do not have traffic lights, signage, or other tools to properly indicate the right of way for both vehicle traffic and crossing users. Therefore, passenger vehicles may not know to yield to pedestrians and cyclists, who in turn may cross the road without watching for oncoming traffic. To exacerbate the unsafe conditions at these crossing, the presence of tall trees obstructs the visibility of users approaching the roadway, making it especially difficult for drivers to decelerate their vehicles in the event of a potential collision.

The Food Garden and Physics Garden are situated to the north of West 16th, in proximity to the northeast corner of the junction. The UBC Botanical Garden is located at approximately 350 meters north from the center of the intersection, toward the west side of SW Marine. It is accessible at the intersection of Stadium Road and SW Marine. According to UBC Campus + Community Planning, the intersection is along the route of the R4 RapidBus which turns from the south approach of SW Marine to West 16th (and vice versa) [2]. There are no bus stops for the R4, or for any other public transit service near the intersection.

5.1.2 Geometric Design

The proposed intersection conforms to requirements within standards and design guidelines, used and recognized in BC. Four engineering manuals/guidelines were referenced in completing the geometric design. These are: The BC MOTI's Supplement to TAC, TAC's Geometric Design Guide for Canadian Roads, BC Active Transportation Design Guide, and AASHTO's Policy on Geometric Design. The most important design criteria and requirements from these guidelines are presented in the tables in Appendix G.

The proposed design focuses on efficient space utilization for improved safety and optimization of traffic flow through the intersection. As shown in the Drawing SP-01 which has been superimposed on the aerial view of the current intersection, the size of the intersection has been significantly reduced, with the removal of slip lanes on the northeast and southeast corners. The design includes dedicated right-turn lanes for vehicles on the south approach (turning onto West 16th) and on the east approach (turning onto SW

Marine), as well as a left-turn lane on the north approach. These lanes are intended to accommodate for the increased volumes of right-turning vehicles during the peak hours, and in reducing delays due to congestion. Furthermore, removing the slip lanes significantly reduces the length of the pedestrian and bicycle crossings on the north, south, and east approaches. This reduction decreases pedestrians' direct exposure to vehicular traffic and the complexity of navigation around the intersection.

From Section 9.7.1 in AASHTO's Policy on Geometric Design, the design of auxiliary lanes should be at least 3m (in width). From Table 9-20, the recommended "Lane Change and Deceleration Distance" for vehicles approaching the intersection at the design speed (50 km/h) is 50m, which takes into consideration the perception-reaction time and the taper length. A straight-line taper is used to incorporate the additional dedicated right-turn lanes from the south and east approaches), and the left turn lane on the north approach. The acceptable taper ratio is 8:1, for design speeds up to 50 km/h. Thus, the minimum taper length is 28.8m (or 36m x 8). As the roadway shoulders terminate near the junction of the intersection, the dedicated right turn auxiliary lanes move into this space.

For the WB-20 design vehicle turning at speeds of 0-15km/h, the minimum corner radius is 14.5m according to the BC Supplement (Table 10, Item 2). Dimensions are presented in planar view within the Drawings. The visual perception of a tighter corner radius can serve as a cue for drivers to reduce their speeds without the need to implement speed humps. Vehicles passing over speed humps generate noise and vibration, and drivers have tendency to avoid these streets altogether [4]. Moreover, speed humps can impede the process of emergency response vehicles by up to 10 seconds per hump, as stated by the City of Surrey [3]. This is especially problematic as both SW Marine and West 16th has been designated as a disaster response route by the province [14]. However, speeding along the northbound lanes of SW Marine remains an issue, especially for vehicles approaching from the south. To combat this issue, the number of lanes has been reduced from 3 to 2, as vehicles on the right-most lane will be required to merge into the adjacent middle traffic lane. Increasing the density of traffic will create tighter spacing between vehicles, necessitating a reduction in speed to maintain safe following distances and avoid collisions. The width of all vehicle lanes is 3.6m, meeting the minimum lane width requirement (of 3.6m) in the BC Supplement (Table F1), and the current width of the lanes at the intersection.

In addition to the bike-on-shoulder lane along SW Marine (on the southbound), a paved roadway shoulder of 3.0m is maintained beside the right-most traffic lane on most roadways (Table F1. Item 4). It is designed to be sufficiently wide, allowing for drivers to pull into the shoulder in the event of an emergency. They also provide access for maintenance crews and construction vehicles to perform routine maintenance inspections and repairs without disrupting traffic flow. However, the shoulder is not designed for passing maneuvers. The existing emergency access road (located approximately 20m from the limit of construction) is maintained, connecting the eastbound and westbound lanes over the grassed median.

Active Transportation Infrastructure & Transit

According to the City of Vancouver’s website on “Signs, signals, and regulations”, green is widely used in North American cities as the standard color for cycling facilities [15]. However, it may not be reasonable to assume that this is a globally recognized standard, or that all users will recognize the meaning of this indication. To ensure clarity and safety for cyclists and pedestrians, clear signage is used to reinforce the meaning of different colors and indicate the presence of cycling facilities.

A dedicated bike-on-shoulder lane is located beside the southbound vehicle of SW Marine, on the west side of the intersection. It offers several benefits, such as increased safety and reduced congestion. In shared lanes, auto drivers often attempt to pass bicycles due to frustration and a general perception of impediment. Providing a dedicated lane reduces the likelihood of accidents caused by vehicles overtaking cyclists too closely or turning into their path, and the risk of collisions (with other vehicles) when changing lanes. As per guidelines, the minimum recommended width is 1.5m or 1.8m (Table F1 and F2, Items 1). Taking into consideration that auto drivers may pull over to the shoulder in the event of an emergency, the bike-on-shoulder is designed to be 3.0m.

It is also important to preserve and maintain the integrity of existing infrastructure for active-move users around the intersection, to minimize disruptions, costs, and negative environmental impacts. The existing pedestrian pathways (refer to Figure 9, approx. 2.3m width) are not sufficiently wide to accommodate both pedestrians and cyclists comfortably. As a cost-effective solution, this pathway will be repaved, widened, and

transformed into two multi-use pathways (MUPs) for pedestrians, cyclists, and other active mode users. Moreover, MUPs can encourage recreational walking and cycling trips, while catering to families and those less accustomed to biking. For safety concerns, the Active Transportation Design Guide recommends that pedestrian sidewalks should not be implemented directly adjacent to vehicle traffic lanes when design speeds exceed 30km/h. The full width of the MUP is 4.0m (as per Table F2, Item 2), and the design speed is 20kph (Table F2, Item 3). Clear lane markings separate pedestrian and bicycle traffic, with commercial reflective pavement marks (between the lanes, providing lighting at night) for additional safety protection [5]. The existing fencing along the pathways will be maintained. Unauthorized motor access of the MUP is prohibited, but emergency and maintenance vehicles may reach the north side MUP through a controlled access point from the shoulder of the westbound lane on W 16th, situated near the limit of construction (refer to IFC Drawings). The longitudinal grade of the existing pathway is sufficient (< 5%) according to guidelines (Table F2, Item 4) and will not be altered for the MUPs.

To facilitate the movement of pedestrians and cyclists at the intersection, sidewalks are implemented on the northeast and southeast corners of the junction. The MUPs are linked to the sidewalks through four access points (refer to IFC Drawings) and terminates at approximately 50m to 70m from the directional approaches (stop line), as pedestrians and cyclists are required to use the MUPs on the east side of the intersection. The width of the sidewalks are 2.5m, exceeding the minimum recommended width is 1.5m in the BC Building Code [1]. Green striped pavement markings in the junction indicate bicycle crossings, safely guiding cyclists through the intersection. The crossing on the east approach (indicated without green color) is to be used by pedestrians and cyclists. The cyclist crossing is 3m wide, and the east crossing is 4m, satisfying the minimum crosswalk width of 2.5m in TAC's Manual of Uniform Traffic Control Devices for Canada (Table F4).

Movement of Pedestrians West of Intersection

Following extensive discussions, it was decided that a pedestrian sidewalk should not be implemented along the southbound lanes of SW Marine. Due to the steep decline in ground elevation towards the ocean, constructing a sidewalk will require significant

adjustments to drainage systems and existing utility infrastructure. Earthworks during construction and significant re-grading of the existing surface will be required, which would elevate the cost of the project. Lower pedestrian traffic volumes are anticipated for the immediate future. There are no major building facilities towards the west side of SW Marine, or bus stops in the vicinity of the intersection as stated. As such, the traffic demand is sufficiently low and the benefit to users is not enough to offset the cost of this additional feature. To travel from the east to the west side of the intersection (and vice versa), pedestrians will use the existing underpass tunnel connecting the Upper Asian Way trail (on the west) with the MUP pathway (on the east). This tunnel is located approximately 130m from the north approach of the intersection.

Maintenance of Buffer with Gardens

One of the primary objectives is to retain the buffer with the Botanical Garden property. While developing the geometric configuration for the roadways, the horizontal alignment of the existing roadway was closely followed. Toward the north of the intersection, the southbound leg has a width and geometry that is very closely aligned with the existing southbound lanes, without significant shifting the alignment towards the west side, where the Botanical Gardens are located. Furthermore, this allows the new design to tie into the existing roadway at a closer distance, lessening environmental disruptions and project costs. The table below summarizes the geometric characteristics of the roadways (leading to the intersection), including the tie-in distance from the stop line of the approach. Away from the junction, the existing grassed median (of approximately 10m) separating the directional vehicle lanes is maintained. It provides a physical separation between opposing lanes of traffic, reducing the likelihood of head-on collisions and crossover accidents. There are further environmental benefits to the environment and to stormwater management, as vegetated medians can reduce runoff and help prevent flooding and erosion. These aspects will be further discussed in the report.

Table 4: Summary of Roadway Lags

Roadway	North Leg (SW Marine Drive)	South Leg (SW Marine Drive)	East Leg (West 16 th Avenue)
Vehicle Lane Width	3.6m	3.6m	3.6m

Right Shoulder Present	Yes (Both)	Yes (Both)	Yes (Both)
Shoulder Width	3.0m (NB); 3.0m (SB Bike-on- Shoulder Lane)	3.0m (EB); 3.0m (WB)	Varies (NB); 3.0m (SB Bike-on- Shoulder Lane)
Bicycle Lane Present	Yes (SB Only)	Yes (SB Only)	No
Bicycle Lane Width	3.0m	N/A	N/A
Median (Separating Directional Vehicles) Present	Yes (Grass)	Yes (Grass)	Yes (Grass)
Approach Crossing	Bicycle Only	Bicycle Only	Pedestrians, Bicycles, All Active-Mode Users
Dedicated Left Turn Vehicle Lane Present	Yes (One)	No	Yes (Two)
Dedicated Right Turn Vehicle Lane Present	No	Yes (One)	Yes (One)
Tie-In Distance from Stop Line of Approach (± 5m)	170m	185m	185m

5.2 Traffic Flow Analysis

To find the current peak hour flow a traffic count was conducted during rush hour(3P.M. – 6P.M). These counts were then projected to the year 2075 so that they could be used for traffic flow analysis. The projection considered the below listed factors:

- Historical traffic count data for roads leading up to UBC (15% every 10 years) [2]
- UBC Housing Increase (-10%) [2]
- UBC Rapid Transit (-10%)
- Safety (10%)

The current and 2075 projected peak hour flows are depicted in the figures below.

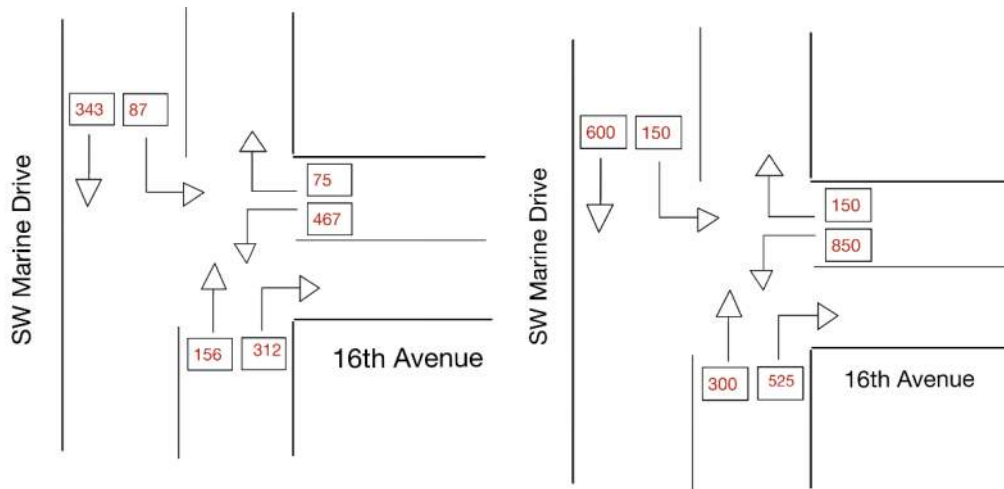

Figure 10: Traffic Projections - now & 2075

To ensure the intersection design would be able to accommodate the 2075 projected traffic; the traffic system discussed earlier in 4.1 was modeled in Synchro with the projected counts. The results of the analysis are displayed in table 5 below.

Table 5: 2075 Traffic Analysis

Max V/C	Intersection Delay	Intersection LOS
0.84	22.0 Seconds	C

These results make it clear that the intersection will be able to handle the traffic flow in 2075 and not be oversized.

More figures on the analysis can be found in Appendix A.

5.3 Signage

Placing signage at visible and appropriate locations is crucial for public safety and ease of navigation. The recommended signage to be placed at the intersection are shown in the IFC Drawings, and they are from the BC MOTI's "Catalogue of Traffic Signs" [6]. As recommended by the BC Active Transportation Design Guide, the Pathway Organization sign (B-G-003 Series) is used along the MUP to separate pedestrian and bicycle traffic. Signs are placed near the south limit of construction (LOC) beside the northbound, the east LOC beside the eastbound, and over the west side curbs on the north approach (near the junction, beside the southbound) for the indication of disaster response routes. Speed signage of 50 km/h will be posted along all directional approaches. No right turning on red signs will be posted on the

southeast and the northeast corners of the intersection. Signage will also be placed to assist pedestrians and cyclists navigating the intersection.

5.4 Geotechnical analysis

Based on the geotechnical assessment conducted by Piteau Associates Engineering, the current geotechnical conditions of the site have been thoroughly evaluated. The static groundwater tables are significantly below the required development grade for the project, with excavation anticipated to extend up to 10 meters below the existing grade level. Consistent with hypotheses formed during the preliminary design stage, the soil profile on site is largely consistent with other areas on campus [13]. This provides a degree of confidence in the accuracy of the geotechnical analysis.

Table 6 provides a description of the observed soil profile for the site, extending up to 20 meters below grade level.

Table 6: Summary of Geotechnical Layers

Depth below grade level (m)	Soil Type
0-1.4	Loose, poorly graded sand
1.4-12.2	Medium-Fine sand; Sandy silt
12.2-15.1	Densely packed, well graded Medium- Fine sand; Silt trace
15.1-19.9	Very dense, well graded, interbedded sands and silts; Gravel traces

5.5 Foundation and Bearing Capacity for Gateway Structure

To ensure that the foundation of the structural gateway would be stable on the site, there was a geotechnical assessment undertaken by GeoPacific Consultants Ltd. Based on the results of this assessment, the footing for the intended gateway structure will be founded on competent, native, dense sandy/silt soil and can be designed for a Serviceability Limit State (SLS) bearing pressure of 150kPa [14]. The factored Ultimate Limit State (ULS) bearing pressure, which will take transient loads such as those induced by wind and earthquakes may be taken as 450kPa.

5.6 Shear Bearing Capacity

Furthermore, a triaxial shear test was conducted on the soil in the area to determine the shear-bearing capacity. The test was to ensure the soil around the intersection could withstand the

load transmitted through it by both the gateway and the vehicles driving along the road. The test was conducted on three different samples, each of which were either unconsolidated undrained, consolidated undrained, or consolidated drained [9]. The controlling shear-bearing capacity across these tests was found to be around 300 kPa, which is in line with what is expected of medium dense sand [10]. The heaviest load that this intersection could be expected to experience would be from a semi-truck with a full-loaded trailer. Through calculations, it was determined that each tire of the 18-wheeler would exhibit a force on the road equal to 198 kPa for 0.10 square meters of area. From this, it is evident that the soil beneath the intersection can withstand the loads it will be subject to as the bearing capacity is well above the maximum expected load.

5.7 Pavement Design

Cross-sectional views of the design are presented in Drawings SP12 and SP13. The amount of paving and subgrade material varies by the location of the section. However, the roadway pavement design constitutes of the following layers in order (from surface to the bottom grade): asphalt, 25mm well-graded base, 75mm well-graded base, and 50mm select granular subbase. This complies with the BC Supplement's requirements for rural freeways (and urban roadways in the Cross-Sections Chapter), where a multi-lane roadway is separated by a median. As multi-use pathways are designed to be accessible and cater to a diverse array of users, a newly paved level surface of 130mm asphalt will be used, with an underlay of 130mm (of 75mm) well graded base.

5.8 Structural Design

The gateway system at SW Marine Drive and W 16th Avenue serves as a welcoming landmark, signaling to road users of their arrival to the UBC campus. Designed with Hollow Structural Steel (HSS) components securely welded and bolted, the structure incorporates hinged supporting columns to withstand dynamic forces. Additionally, concrete footing piles at each end provide a stable foundation, reinforced with steel rebar. Integrated with Monocrystalline Solar Panel Kits (AX30), the digital display aligns with UBC's sustainability goals. This approach reflects a commitment to functionality, sustainability, and aesthetic appeal, enhancing the sense of arrival within the UBC Vancouver community.

The structure experiences a combination of forces, including compression, tension, and shear, due to its own weight and external loads such as wind and seismic forces. Calculations for the

resultant forces as well as are shown in Appendix A. Additionally moments, or rotational forces, may occur at points where the structure is supported or where loads are applied asymmetrically. The HSS members, serving as webs and supporting beams, are designed to withstand these forces and moments. The vertical HSS members provide vertical support, while the horizontal beams distribute loads horizontally.

Bolted joints are used to connect various structural elements, such as HSS members and supporting columns, to distribute forces and moments effectively. High-strength ASTM A307 bolts will be used to provide secure connections and prevent loosening or failure under load. Proper bolt tightening procedures, including torque specifications, are followed to ensure reliable joint performance. Welding will be employed to join HSS webs to horizontal beams, providing continuous load transfer and enhancing structural stability. The welds will be fillet welds and will have a thickness of 7mm as per CSA W59.b.

To ensure structural integrity, S-Frame was utilised to undertake a comprehensive structural analysis to supplement the hand calculations done. This analysis provided the following for each member in the structure:

- Axial force
- Shear force
- Deflection
- Moment
- Stress
- Support reaction forces

Diagrams illustrating these values are displayed in Appendix A.

5.9 Foundation Design

The chosen foundation type for the gateway system is footing piles, also known as drilled shafts or caissons. Footing piles are deep foundation elements that are drilled or excavated into the ground and filled with concrete to provide support for vertical loads.

The footing piles have a diameter of 0.65m (650mm) and a height of 2.8m (2800mm). These dimensions are determined based on the structural requirements of the gateway system and the anticipated soil bearing capacity. The diameter and height of the footing piles are

designed to distribute the loads from the structure evenly and prevent excessive settlement or tilting. They are constructed using concrete with a compressive strength of 30 MPa. This ensures that the piles can withstand the applied loads of 49.8 kN shown in Appendix A, as well as expected environmental conditions. Each footing pile incorporates eight 15m long rebar (reinforcing bars), which are secured with 10M rebar ties. The reinforcement enhances the structural capacity of the piles and prevents cracking or failure under load.

Throughout the construction process, quality control measures are implemented to ensure that the footing piles meet the specified standards and requirements.

Various tests, such as concrete strength tests and integrity tests, may be conducted to verify the quality and performance of the foundation elements.

5.10 Electrical Implementation

The gateway will contain several electrical components, including a digital screen, solar panels, and electrical wiring and conduits. Figure 11 displays the circled utilities box, which is 270m away from the gateway. Although the primary energy source of the gateway screen is the solar panels, it is essential that there be a secondary energy source for the nighttime display. The wiring will be below ground and will be routed through conduits to protect it from the environment.



Figure 11: Electrical Wiring Plan

5.11 Hydrological analysis

Hydrologic analysis is crucial, particularly in the context of the project area, SW Marine Drive, and 16th Avenue, situated on a peninsula. This unique geographical location emphasizes the importance for understanding the water cycle within the project area,

particularly concerning surface water flow and stormwater management. Being surrounded by water on three sides, the area is susceptible to the influences of coastal weather patterns, and higher risks of flooding. An initial hydrological analysis was conducted, and it involves the assessment of various hydrologic components, including precipitation, runoff, and their interactions with land use, terrain, and climate patterns. This section describes the existing utilities, key issues, our design criteria, and the approaches taken to meet these design expectations.

5.11.1 Regional Rainwater Flow

Following the Region Flood Frequency, the assessment of regional rainfall intensity is also fundamental for understanding the potential for heavy precipitation events that could lead to flooding and stormwater runoff issues. Using the precipitation data provided by Environment Canada and the HydroGeo Study from Piteau Associates to estimate the rainfall in a 100-year storm event. The precipitation over 24 hours is depicted in figure 12 below.

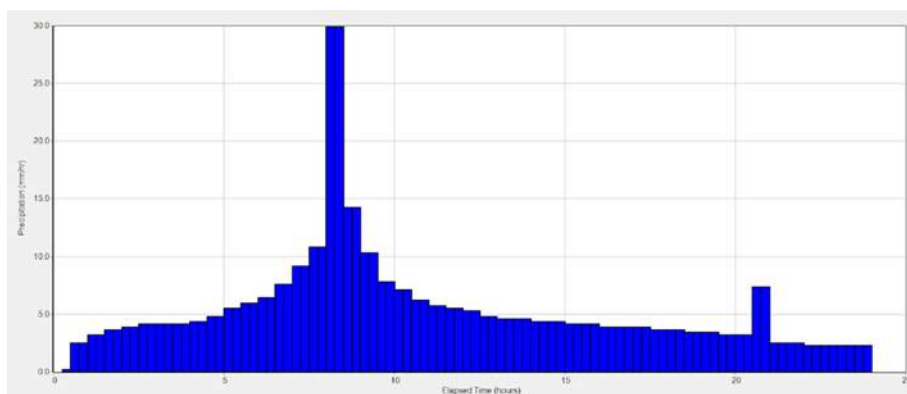

Figure 12:24-hour precipitation in 1:100 year storm event

The Intensity-Duration-Frequency (IDF) curves shown below are developed from historical meteorological data and their expected return periods. These curves are crucial in determining the design standards for the drainage and green infrastructure.

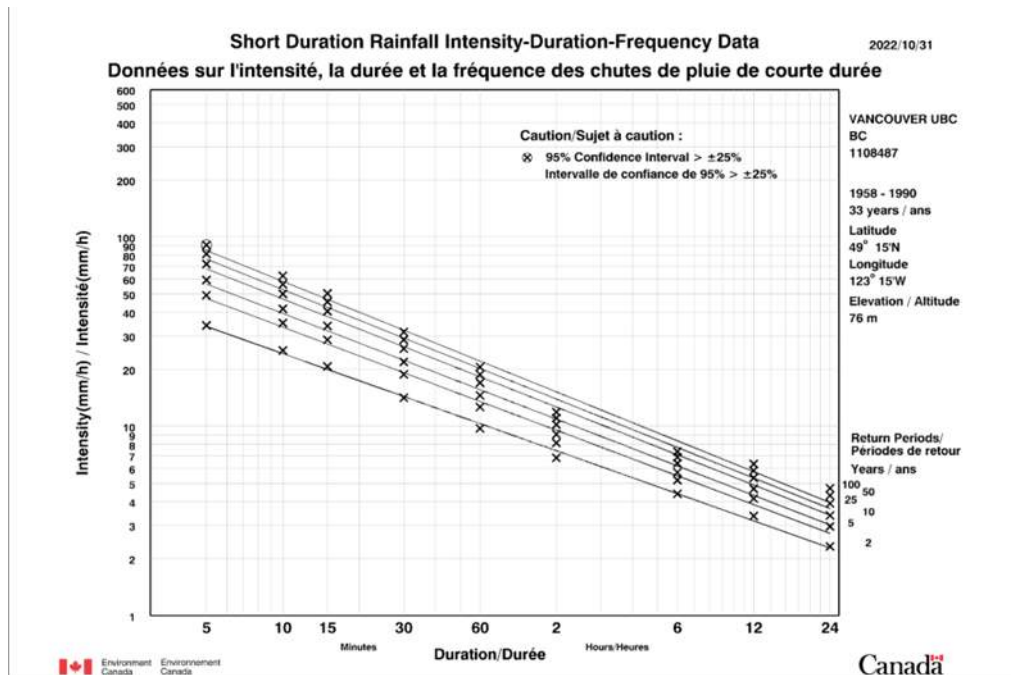

Figure 13: Intensity-Duration-Frequency curves for Vancouver BC

These IDF curves were modelled in EPASWMM to estimate peak runoff rates, impervious runoffs and pervious runoffs in the surrounding sub-catchments of the UBC’s Vancouver campus and the project area.

5.11.2 Existing Conditions

Following the UBC Integrated Stormwater Management Plan, we realize that there are distinct challenges for the area. The intersection of SW Marine Drive and W 16th Avenue falls under the 16th Avenue Catchment as shown in the UBC drainage map below. The catchment leads to the SW Botanical Garden outfall which flows into steep ravines in the west of UBC Botanical Gardens and eventually into the Musqueam Marsh, an area of estuarine marsh and mudflats on the North Arm of the Fraser River. This side of the UBC campus is also vulnerable to cliff erosion. With the intersection being one of the important entry points to the UBC campus, the existing utilities need upgrading. Following the Region Flood Frequency, the assessment of regional rainfall intensity is also fundamental for understanding the potential for heavy precipitation events that could lead to flooding and stormwater runoff issues. EPASWMM was used to estimate peak runoff rates, impervious runoffs and pervious runoffs in the surrounding sub-catchments of the UBC’s Vancouver campus and the project area. Using available information from the IDF curves mentioned earlier, the model created derives the following values for the sub catchments around SW Marine Dr. and 16th Avenue.

Table 7: Sub catchments and their runoffs within the project area

Sub catchments	Total Precip (mm)	Imperv Runoff (mm)	Perv Runoff (mm)	Peak Runoff (LPS)
1	129.03	42.76	39.52	14.77
2	129.03	29.89	45.12	22.87
3	129.03	79.42	22.79	49.53
4	129.03	57.6	33	39.81

Our analysis also concurs with UBC Integrated Stormwater Management Plan which indicates that the current utilities are undersized for the increasing population. Following the EPASWMM analysis, the volume for runoff in the project area was calculated by approximating the impervious area from the 4 sub catchments designed in the model using satellite images, the non-permeable area and developed areas of the catchment and the sum of these areas was used. An additional 25% factor was introduced to account for the expected future development of the SW Marine Drive and 16th Avenue intersection. The total impervious area was calculated to be 10435.11 m^2 and the total volume calculated to design for is 617 m^3 . The system has a discharge rate of approximately $0.75 \frac{\text{m}^3}{\text{s}}$.

5.12 Environmental Considerations

The redesign of the SW Marine Drive and 16th Avenue intersection has been implemented with adherence to UBC Environmental Protection policy and The BC Environment Management Act. Given the intersection location's proximity to sensitive ecological areas such as UBC botanical gardens, environmental sustainability should be prioritized. Measures such as stormwater management, habitat preservation, pollution control, use sustainable material, energy preservation, and pedestrian and cyclists' safety has been taken to consideration. Management of stormwater has been implemented through usage of bioswales, raingardens and placement of detention tank for containing waste.

The habitat preservation has been taken to consideration by adhering to the "BC Wildlife Tree Committee Mandate". The reconstruction of the roadway is to have no impact to surrounding green structures such as the UBC botanical garden. To adhere UBC's Climate Action Plan, low-emission construction equipment and vehicles to minimize Co2 emissions during the construction phase is to be used. Additionally, sediment and erosion control measures such as silt fences, sediment basins, and erosion control blankets should be

employed to prevent soil erosion and minimize sediment runoff into nearby water bodies. Furthermore, a third-party waste management company is to be hired to ensure the proper disposal of construction debris and materials. To promote sustainability and energy preservation, the gateway system of the intersection is designed to operate with solar power. Lastly, the intersection has been redesigned to encouraging active modes of transportation, by implementing a safe speed limit, adequate roadway shoulder size, pedestrian crosswalk and traffic lights.

All matters regarding landscape and softscape on site shall adhere BC MOTI Standard Specification for Highway Construction – Volume 2 **Section 751, 754 766, and 769.**

6. Schedule and Construction

A construction schedule following the phasing and requirements of this project is displayed in Appendix B. The estimated time intervals of this schedule was assigned utilizing the BC MOTI Tender & Contract Documentation Guide and WorkSafe BC Regulations.

6.1 Construction Requirements

To construct a durable roadway, adherence to municipality by-laws and requirements is crucial. Requirements for the roadway construction are ensuring the compliance with engineering design specification and standard through regular coordination meetings, implementation of quality control plan for the construction material and alignments, execution traffic control and safety measure in accordance with WorkSafe BC. In addition, the reconstruction of the intersection should comply with BC Environment Management Act and UBC's environmental protection policy. Moreover, the site management team should keep a record of all site action and design coordination to insure legitimacy of the process.

6.2 Construction Phasing

To reduce traffic disruption, one lane is to remain free at all times during construction; thereby, a detailed phasing plan was developed. This plan includes a pre-construction phase, three construction phases and project closeout phase. Figure 14 outlines activities to be performed at each phase.

Starting on **May-06-2024**, Phase I would take place on the right lane of north bound and take over until north bound of 16th avenue. This phase includes all critical steps such as demolish,

pipng, electrical work roadway construction, sidewalk construction, traffic light installment, and catch basin placement. Moreover, Phase II starts on June-05-2024, this and would include critical construction steps alongside with gateway construction. Lastly, the third phase includes critical steps in with addition of detention tank placement. The construction schedule also includes a pre-construction and project closeout. Preconstruction phase includes permits, site mobilization and site surveying. Closeout of the project would include roadway markings, signage placement, Operation manual documentation and finally, site demobilization. The project is set to be handed over to client on **Sept-04-2024**, prior to start of academic year.

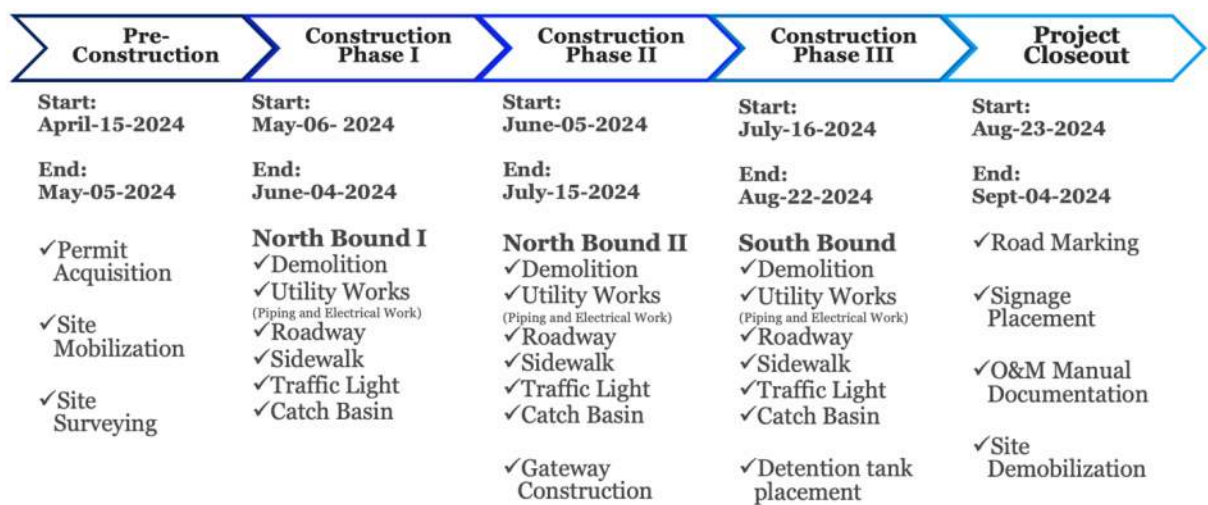

Figure 14: Summary of Construction Schedule

6.3 Traffic Management Plan

To ensure a smooth construction operation, a traffic management plan should be in place. This plan includes different phasing of construction, crew allocation for construction flaggers as well as equipment and signage required for road user notification. According to BC MOTI Construction Sign Guide, the temporary signs to be used during construction are listed in chart below:

Table 8: Temporary Sign Allocation [9]

Sign	Purpose
C-002-2 Series	Crew Working symbol Maximum () km/h (R-004)
C-004 Series	Crew Working symbol
C-018-3A Series	Road Work AHEAD ARROW
C-027 Series	Traffic Control Paddle STOP or SLOW - Double Sided

C-042-SLR Series	Flagger Warning (Double-sided Sign)
C-047-1 Series	Temporary Road Lines
C-183-Ta Series	Cyclists use caution, construction affects road conditions

Figure 15 represents the phasing of the roadway to manage traffic during construction time.

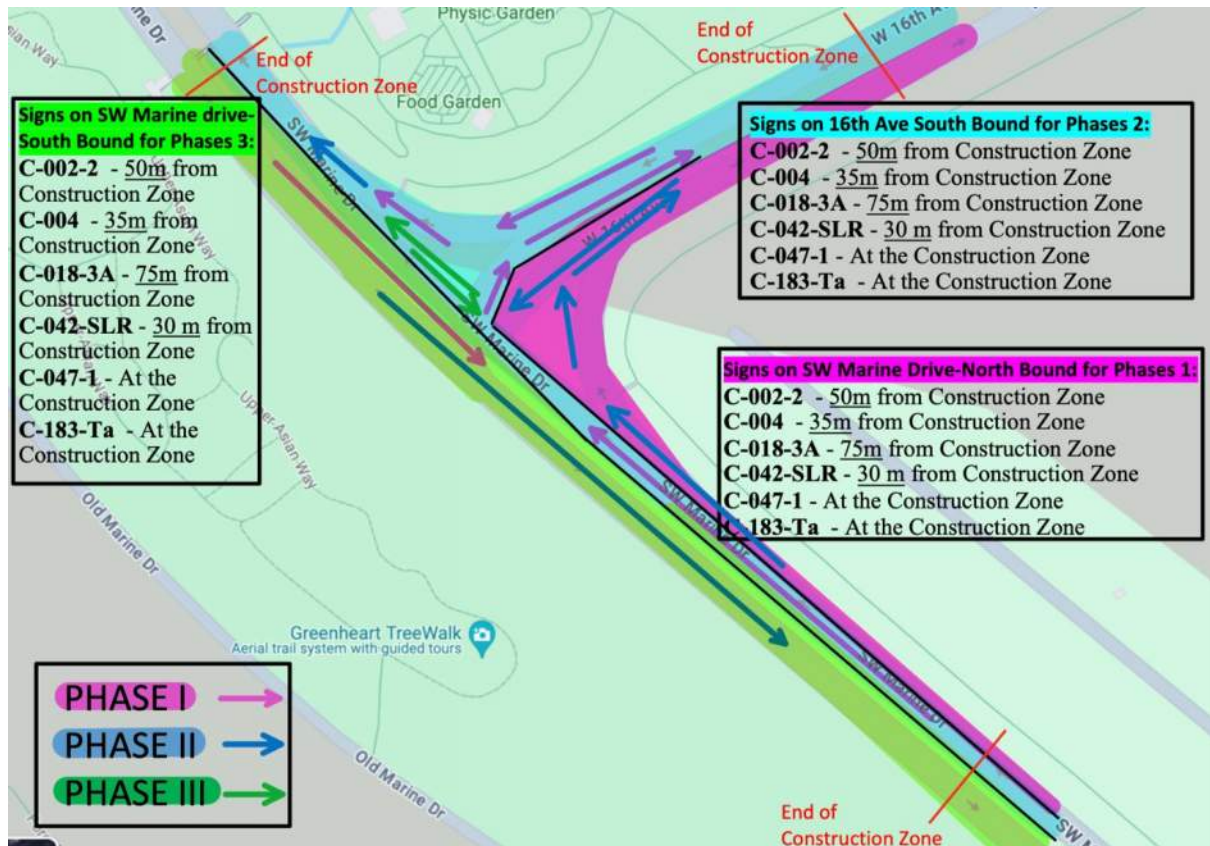

Figure 15: Construction Phasing Map

As displayed on the construction phasing map, the three phases are Phase I (highlighted in Purple), Phase II (highlighted in blue) and Phase III (highlighted in green). Temporary lanes will be allocated to directions of traffic which get impacted by the construction activities. The traffic direction of each phasing is outline with same order and color coordination. Furthermore, sign allocations for each phase are outlined on the map. Each phase of traffic will have two construction flaggers guiding traffic utilizing a traffic paddle sign (C-027). The flaggers are to stand at the start of the construction zone wearing high-visibility construction gear.

7. Risk Assessment

To ensure a timely delivery of the project, a comprehensive risk assessment was undertaken to outline a variety of risks the project team may encounter. Subsequently, control systems were allocated to each risk to effectively minimize them. These include:

Unexpected Site and geotechnical conditions: During the construction process, discovering unexpected subsurface conditions on site such as unstable soil can lead to a delayed construction schedule and additional costs. As described in previous sections, there have been a thorough geotechnical analysis undertaken on site. However, there still remains an element of risk. Incorporating some level of flexibility into the schedule to accommodate potential variations in the site condition will aid in mitigating this risk. Additionally, regular monitoring during construction will be implemented to ensure early identification -and timely adjustment- of any unforeseen challenges regarding the site conditions.

Political Risk: Changes in political leadership during the course of course of construction presents uncertainty in support for the project. This includes shifts in funding priorities or delays in approvals due to political factors. To mitigate political risk, it is essential that we maintain open communication channels and strong relationships with the relevant government authorities and stakeholders. Additionally, securing support from multiple levels of government will provide resilience against these uncertainties.

Budget overruns: Unanticipated construction costs and increases in material prices may lead to the project cost exceeding the initially estimated budget, as well as design revisions due to changes in the scope of work. To mitigate these risks, a rigorous cost estimation and budget plan was implemented during the detailed design to quantify all potential costs, including a 12% contingency in the budget. Additionally, cost control measures including regularly monitoring trends in expenditure will be ongoing to identify cost saving opportunities. Moreover, there will be an established, clear change management procedure for evaluating and approving changes in the scope of work to minimize the impact on the budget.

Construction Delays: Delays due to unforeseen weather conditions and site challenges such as delays in material delivery may lead to interruptions in the project schedule. To minimize these delays, meticulous planning and scheduling of activities has been undertaken to mitigate delays. This involved identifying and prioritizing critical path activities and

establishing realistic timelines. Additionally, contingency plans and a sufficient buffer for the schedule has been considered to provide flexibility for unforeseen challenges.

Traffic Management: During the construction period, we aim to maintain a smooth traffic flow and will prioritise public safety. Thus, we plan to complete majority of the activities during summer, as there are lower traffic activity levels in that period. To ensure our traffic management goals are met, a comprehensive traffic management plan has been developed in collaboration with relevant stakeholders and includes strategies to minimize traffic disruptions with alternative route, and temporary traffic control measures. It also outlines managing lane closures, temporary traffic signals, and pedestrian access. Furthermore, there will be regular communication with the public regarding traffic impacts to ensure alignment in expectations.

8. Cost Estimate

The total estimated project cost for the planning, demolition and construction of the W 16th Ave. and Marine Dr. Intersection is **\$4,235,560.00 CAD**. The planning of the project costs \$679,288.62 CAD, this cost includes community consultation plan, construction staffing requirements and construction general requirement cost. The construction and material cost include roadway, storm water management, gateway, traffic, and miscellaneous construction cost. Other eligible costs such as 5% design allowance and 4% construction bond has been allocated in accordance with “2020 Standard Specifications for Highway Construction Volume 1 of 2”. Also, the total design and engineering cost is \$480,640.00 CAD. Notably, the estimated cost includes a 12% contingency. Figure 16 showcases the cost breakdown of the projects total cost. The Class A cost estimate is shown in Appendix C.

TOTAL PROJECT COST

■ Project Planning ■ Design / Engineering ■ Construction / Materials ■ Other Eligible Costs

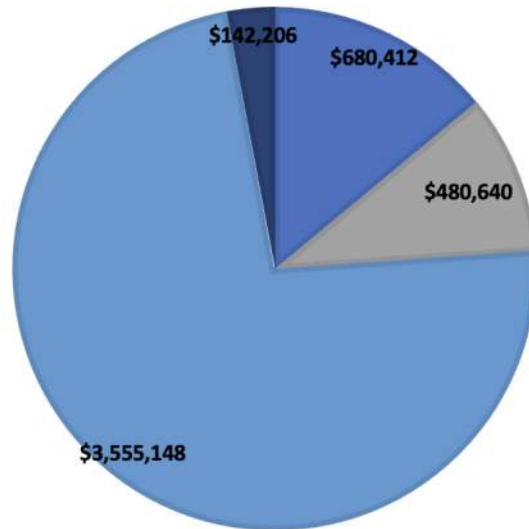

Figure 16: Project Cost Breakdown

9. Service Life Maintenance Plan

The 16th Avenue and SW Marine Drive Intersection is design to have a 100 years of service life. The traffic engineering team suspects the growth year to be 2075 with a peak hourly volume of 850 Vph/CL. The intersection is designed for use of WB-20 Truck.

To sustain this intersection, a maintenance plan has been formulated with adherence to “2018-19 BC MOTI Maintenance Specification”. This plan includes maintenance of surface, drainage, winter, roadside, structure, traffic, and network. Refer to Appendix F for the standard maintenance plan the contractor must be adhered.

The maintenance plan outlines the minimum acceptable standards of completed work applicable to all provincially owned roads. Further adjustments to the plan are needed once the contractor has completed construction.

Conclusion

The SW Marine Drive and W 16th Avenue Redesign project addresses critical challenges which the current intersection faces. Aligning with UBC's sustainability and safety commitments, the redesign prioritizes pedestrian and cyclist safety, enhances stormwater management, and implements a visual gateway to the UBC campus. Through the

implementation of a semi-actuated traffic light system, structural gateway, and advanced stormwater management techniques, the project seeks to enhance user safety and efficiency.

Moving forward, it is essential to engage the community, monitor the construction progress, and adapt to possible challenges to ensure the long-term success intersection redesign. With its positive impact on transportation and environment the SW Marine Drive and W 16th Avenue redesign displays UBC's commitment to innovation, sustainability, and community development.

References

- [1] B. C. Ministry of Housing, British Columbia Building Code 2024, <https://www2.gov.bc.ca/gov/content/industry/construction-industry/building-codes-standards/bc-codes> (accessed Apr. 10, 2024).
- [2] “Transit,” Transit | UBC Campus & Community Planning, <https://planning.ubc.ca/transportation/transit> (accessed Apr. 10, 2024).
- [3] “Traffic calming,” City of Surrey, <https://www.surrey.ca/services-payments/parking-streets-transportation/roads-in-surrey/traffic-calming> (accessed Apr. 10, 2024).
- [4] Pros and cons of speed bumps, <http://static1.1.sqspcdn.com/static/f/1235732/22103763/1362529181470/PROS+AND+CONS+OF+SPEED+BUMPS.pdf?token=BYQNZCdVF7xmzv0VvnWhkRpoePg%3D> (accessed Apr. 10, 2024).
- [5] “Canada,” 3M Canada, https://www.3mcanada.ca/3M/en_CA/p/d/b00010878/ (accessed Apr. 10, 2024).
- [6] M. of T. and Infrastructure, “Traffic signs & pavement marking,” Province of British Columbia, <https://www2.gov.bc.ca/gov/content/transportation/transportation-infrastructure/engineering-standards-guidelines/traffic-engineering-safety/traffic-signs-markings> (accessed Apr. 10, 2024).
- [7] S. User, “Soil Bearing Capacity,” My Site, <https://www.geotechdata.info/parameter/bearing-capacity> (accessed Apr. 10, 2024).
- [8] “Triaxial shear testing of soils, understanding methods and equipment,” GlobalGilson.com, <https://www.globalgilson.com/blog/triaxial-shear-test-of-soil> (accessed Apr. 10, 2024).
- [9] “Section 5.0 | construction signs - gov.bc.ca,” BC MOTI, https://www2.gov.bc.ca/assets/gov/driving-and-transportation/transportation-infrastructure/engineering-standards-and-guidelines/traffic-engineering-and-safety/traffic-engineering/traffic-signs-and-pavement-markings/standard-traffic-signs/standard-traffic-signs/construction_signs.pdf (accessed Apr. 1, 2024).
- [10] “Guide to cost predictability in construction:,” BC CCA, <https://www.cca-acc.com/wp-content/uploads/2016/07/GuideCostPredictability.pdf> (accessed Apr. 10, 2024).
- [11] “Introduction schedule 1 section 1,” BC MOTI, https://www2.gov.bc.ca/assets/gov/driving-and-transportation/transportation-infrastructure/highway-bridge-maintenance/highway-maintenance/maintenance-agreements/maintenance-specifications/schedule_1a_specifications_revised_2020-02-01.pdf (accessed Apr. 10, 2024).
- [12] Piteau Associates Engineering Ltd. (2002). Hydrogeological and Geotechnical Assessment of Northwest Area UBC Campus, Vancouver. UBC Properties Trust.

- [13] Government of Ontario. (n.d.). *Understanding stormwater management: An introduction to stormwater management planning and design*. Retrieved from <https://www.ontario.ca/page/understanding-stormwater-management-introduction-stormwater-management-planning-and-design>
- [14] C. of Delta, *Lower Mainland Disaster Response Route Network*.
- [15] C. of Vancouver, “Signs, signals, and regulations,” City of Vancouver, <https://vancouver.ca/streets-transportation/signs-signals-regulations.aspx> (accessed Apr. 10, 2024).

Appendix A: Supplementary Technical Information

Structural Gateway S-Frame analysis

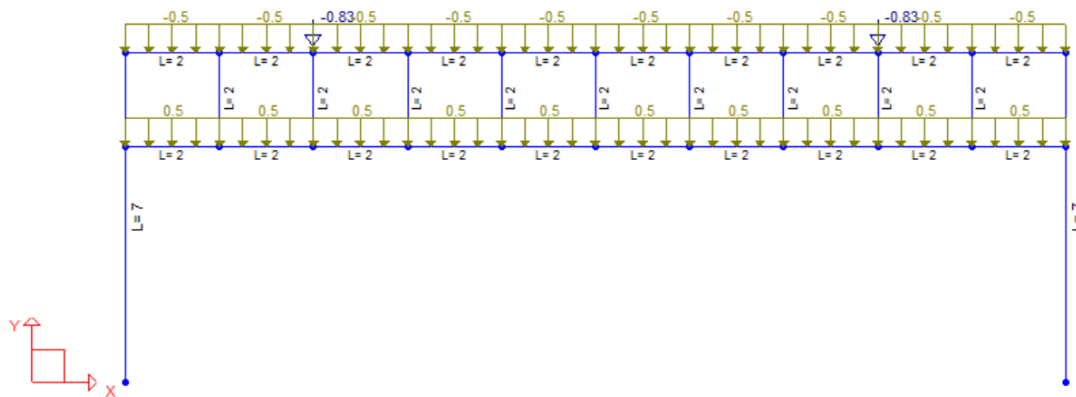

Figure 17: Member lengths and forces



Figure 18: Axial force analysis for each member

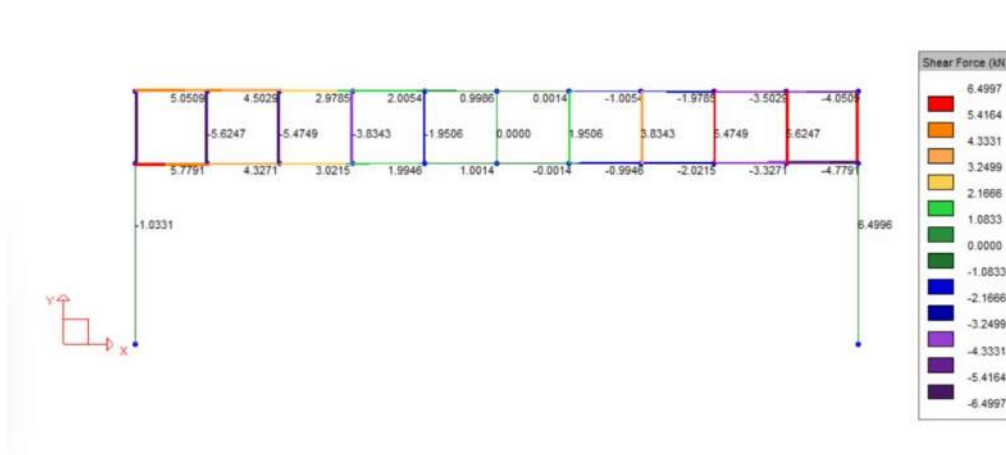

Figure 19: Shear force analysis for each member

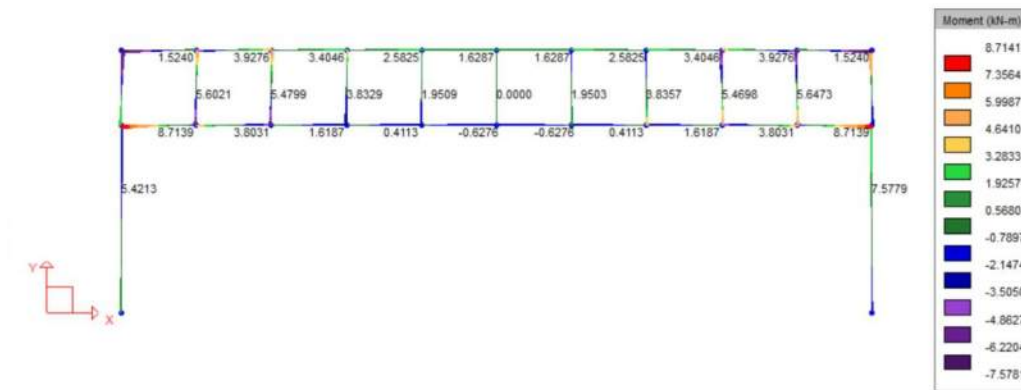

Figure 20: Maximum moment on each member

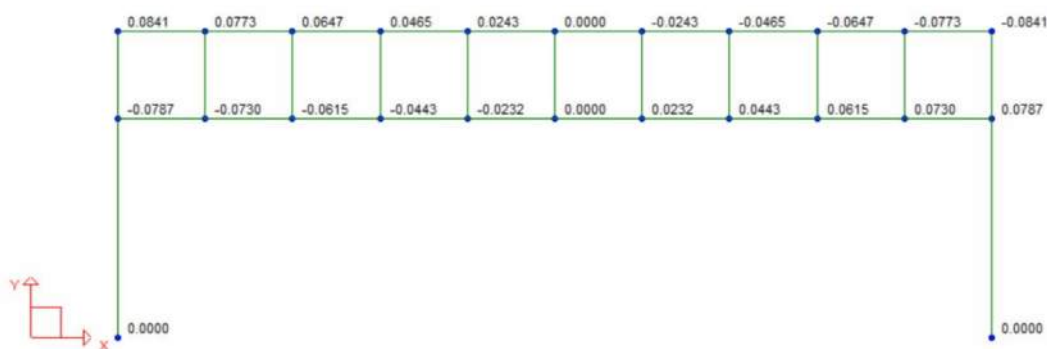

Figure 21: Maximum displacement on each member

Gateway Design Sample Calculations

Column			Beam			Bars		
HS254x254x16			HSS178x178x16			HSS127x127x13		
Item	Quantity	Unit	Item	Quantity	Unit	Item	Quantity	Unit
D	254	mm	D	178	mm	D	127	mm
B	254	mm	B	178	mm	B	127	mm
T	16	mm	T	16	mm	T	13	mm
Mass	114	kg/m	Mass	75.6	kg/m	Mass	42.3	kg/m
A	14500	mm ²	A	9640	mm ²	A	5390	mm ²
Ix	134	mm ⁴	Ix	40.6	mm ⁴	Ix	11.3	mm ⁴
Iy	134	mm ⁴	Iy	40.6	mm ⁴	Iy	11.3	mm ⁴

Gateway Dimensions			Considered Loads			Load Combinations		
Item	Quantity	Unit	Load	Amount	Unit	Case	Principal Loads	Companion Loads
Length (Beam)	20	m	Snow	4	kN/m ³	1	1.4D	
Length (Column)	7	m	Wind	19.03	kPa	2	(1.25D or 0.9D) + 1.5L	1.0S or 0.4W
Length (Screen)	9	m				3	(1.25D or 0.9D) + 1.5S	1.0L or 0.4W
Width (Screen)	1.4	m				4	(1.25D or 0.9D) + 1.4W	0.5L or 0.5S
Dist Between Beams	2	m				5	1.0D + 1.0E	0.5L + 0.25S

Items to be Calculated				
Items	Amount	Unit	Amount to be used	
SW (Beam)	1512	kg		+ 2kN/2 = 1kN for LED screen
SW (Column)	798	kg		+ 4 x (5.2kg x 9.81 / 1000) * 1/2 = 0.102kN
SW (Girdir)	84.6	kg	10	for 4 solar panels
Total Weight		5466	kg	
Load on Footing (SW)		2733	kg	
		26.81073	kN	26.8 + 1 + 0.102 = 27.9 kN

$$P_f = 1.25 (27.9 \text{ kN}) + 1.4 (20.7 \text{ kN}) (\frac{1}{2}) + 0.5 (1.85 \text{ kN}) (\frac{1}{2}) = 49.8 \text{ kN}$$

wind load
snow load

Assuming max allowable bearing Pressure = 150kPa
(Dense or compact sand or gravel soil)

$$SBC = 150 \text{ kN/m}^2$$

$$\text{Area of HSS} = 0.254 \text{ m}^2$$

$$\text{Load} = 49.8 \text{ kN}$$

$$\text{Area of footing} = \frac{49.8 \text{ kN}}{150 \text{ kN/m}^2} = 0.332 \text{ m}^2$$

$$0.332 \text{ m}^2 = \frac{1}{4} \pi d^2$$

$$d = 0.65 \text{ m}$$

$$150 \text{ kPa} = \frac{27.9 \text{ kN}}{\frac{1}{4} \pi (0.65)^2} + 23.5 \frac{\text{kN}}{\text{m}^3} \times h$$

$$h = 2.8 \text{ m}$$

Synchro Analysis:

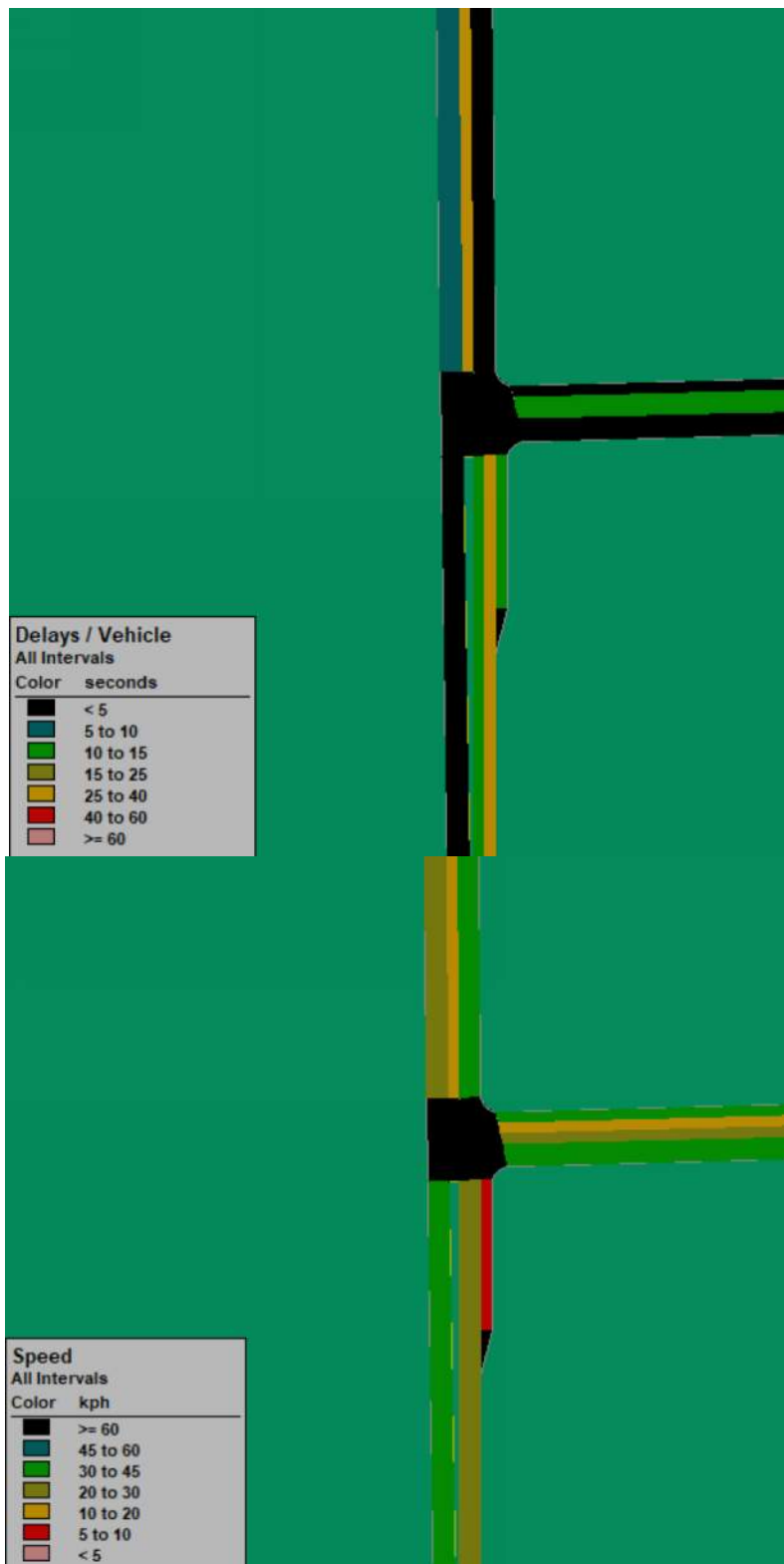

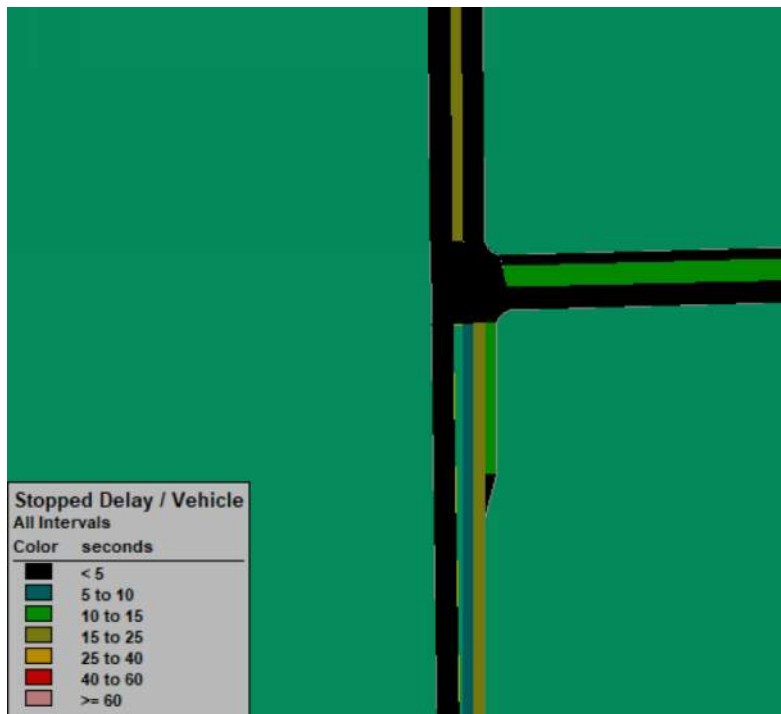

LANE WINDOW	←		↑		↓	
	WBL	WBR	NBT	NBR	SBL	SBT
Lanes and Sharing (#RL)	↔↔	↔	↕↔	↔	↔↔	↕↕
Ideal Satd. Flow (vphpl)	1900	1900	1900	1900	1900	1900
Lane Width (m)	3.6	3.6	3.6	3.6	3.6	3.6
Grade (%)	0	—	0	—	—	0
Area Type	Other	—	Other	—	—	Other
Storage Length (m)	0.0	0.0	—	50.0	0.0	—
Storage Lanes (#)	—	—	—	1	—	—
Total Lost Time (s)	4.0	4.0	4.0	4.0	4.0	4.0
Leading Detector (m)	15.0	15.0	15.0	15.0	15.0	15.0
Trailing Detector (m)	0.0	0.0	0.0	0.0	0.0	0.0
Turning Speed (km/h)	25	15	—	15	25	—
Right Turn Channelized	—	None	—	None	—	None
Curb Radius (m)	—	—	—	—	—	—
Add Lanes (#)	—	—	—	—	—	—
Lane Utilization Factor	0.97	1.00	0.91	0.91	0.91	0.91
Right Turn Factor	1.000	0.850	0.930	0.850	1.000	1.000
Left Turn Factor (prot)	0.950	1.000	1.000	1.000	0.950	0.999
Saturated Flow Rate (prot)	3433	1583	3125	1441	1610	3387
Left Turn Factor (perm)	0.950	1.000	1.000	1.000	0.950	0.944
Right Ped Bike Factor	1.000	1.000	0.991	1.000	1.000	1.000
Left Ped Factor	1.000	1.000	1.000	1.000	1.000	1.000
Saturated Flow Rate (perm)	3433	1583	3125	1441	1610	3200
Right Turn on Red	—	No	—	No	—	—
Saturated Flow Rate (RTOR)	0	0	0	0	0	0
Headway Factor	1.00	1.00	1.00	1.00	1.00	1.00

VOLUME WINDOW	↙	↘	↑	↗	↖	↓
	WBL	WBR	NBT	NBR	SBL	SBT
Traffic Volume (vph)	850	150	300	525	150	600
Conflicting Peds. (#/hr)	0	0	—	0	0	—
Conflicting Bikes (#/hr)	—	0	—	10	—	—
Peak Hour Factor	0.92	0.92	0.92	0.92	0.92	0.92
Growth Factor	1.00	1.00	1.00	1.00	1.00	1.00
Heavy Vehicles (%)	2	2	2	2	2	2
Bus Blockages (#/hr)	0	0	0	0	0	0
Adj. Parking Lane?	No	No	No	No	No	No
Parking Maneuvers (#/hr)	—	—	—	—	—	—
Traffic from mid-block (%)	0	—	0	—	—	0
Link OD Volumes	—	—	—	—	—	—
Adjusted Flow (vph)	924	163	326	571	163	652
Lane Group Flow (vph)	924	163	611	286	143	672

TIMING WINDOW	↙	↘	↑	↗	↖	↓
	WBL	WBR	NBT	NBR	SBL	SBT
Lanes and Sharing (#RL)	↕↕	↕	↕↕	↕	↕	↕↕
Traffic Volume (vph)	850	150	300	525	150	600
Turn Type	—	Over	—	Over	Prot	—
Protected Phases	8	1	2	8	1	6
Permitted Phases						
Detector Phases	8	1	2	8	1	6
Minimum Initial (s)	4.0	4.0	4.0	4.0	4.0	4.0
Minimum Split (s)	20.0	8.0	20.0	20.0	8.0	20.0
Total Split (s)	22.0	12.0	21.0	22.0	12.0	33.0
Yellow Time (s)	3.5	3.5	3.5	3.5	3.5	3.5
All-Red Time (s)	0.5	0.5	0.5	0.5	0.5	0.5
Lead/Lag	—	Lead	Lag	—	Lead	—
Allow Lead/Lag Optimize?	—	Yes	Yes	—	Yes	—
Recall Mode	None	None	Max	None	None	Max

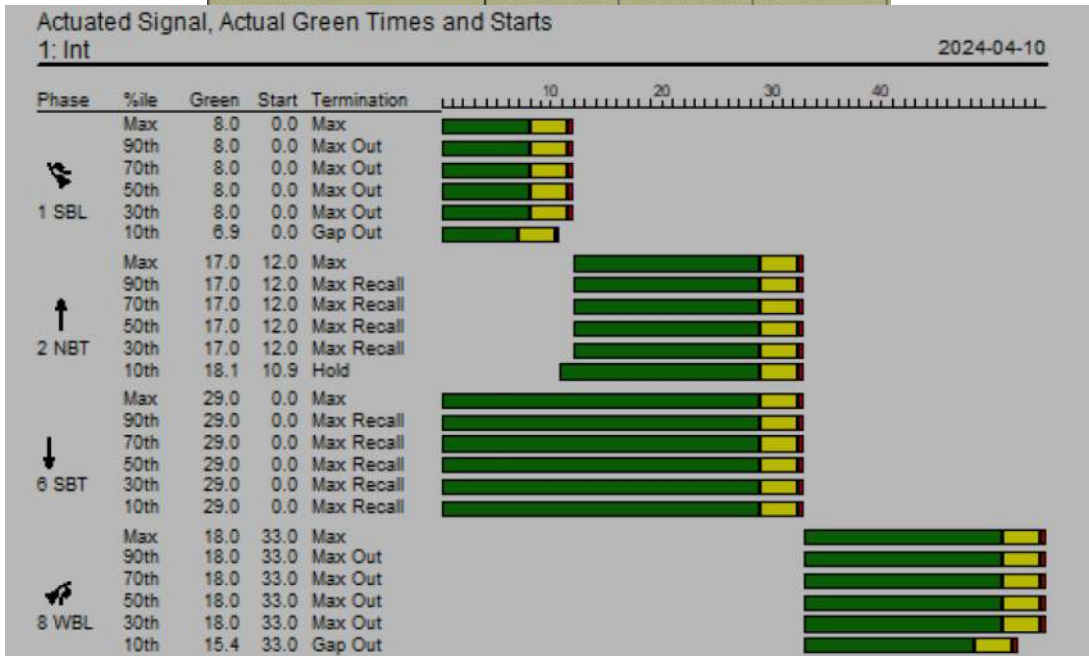

Appendix B: Schedule Gantt Chart



Redesign of 16th Ave and Southwest Marine Drive Project Schedule

Task #	Task	Duration	Start	Finish	April	May	June	July	August	September
Preconstruction										
1	Permit Aquisition	12	15-Apr-24	05-May-24	■	■				
2	Site Mobilization	6	28-Apr-24	04-May-24		■				
3	Site Surveying	2	04-May-24	06-May-24		■				
Phase 1 - North Bound I										
3	Demolision	7	06-May-24	12-May-24		■				
4	Utlilty Works (Piping + Electrical)	6	13-May-24	18-May-24		■				
5	Roadway Construction	8	18-May-24	26-May-24		■				
6	Sidewalk Construction	5	23-May-24	27-May-24		■				
7	Traffic Light Placement	5	28-May-24	01-Jun-24		■				
8	Catch Basin Placement	4	01-Jun-24	04-Jun-24		■				
Phase 2 - North Bound II										
9	Demolision	8	05-Jun-24	12-Jun-24			■			
10	Utlilty Works (Piping + Electrical)	8	13-Jun-24	20-Jun-24			■			
11	Roadway Construction	7	21-Jun-24	27-Jun-24			■			
12	Sidewalk Construction	6	27-Jun-24	02-Jul-24			■			
13	Traffic Light Placement	3	03-Jul-24	05-Jul-24			■			
14	Catch Basin Placement	6	06-Jul-24	11-Jul-24			■			
15	Gateway Construction	3	12-Jul-24	15-Jul-24			■			
Phase 3 - South Bound										
16	Demolision	6	16-Jul-24	22-Jul-24				■		
17	Utlilty Works (Piping + Electrical)	5	23-Jul-24	28-Jul-24				■		
18	Roadway Construction	10	29-Jul-24	08-Aug-24				■		
19	Sidewalk Construction	4	09-Aug-24	13-Aug-24				■		
20	Traffic Light Placement	2	14-Aug-24	16-Aug-24				■		
21	Catch Basin Placement	3	17-Aug-24	20-Aug-24				■		
22	Detention Tank Placement	1	21-Aug-24	22-Aug-24				■		
Phase 4 - Project Closeout										
23	Road Markings	3	23-Aug-24	25-Aug-24					■	
24	Signage Placement	4	26-Aug-24	30-Aug-24					■	
25	O&M Manual Documentation	4	31-Aug-24	04-Sep-24					■	
26	Site Demobilization	4	31-Aug-24	04-Sep-24					■	

Appendix C: Cost Estimate Details

**Investing in Canada Infrastructure Program
Green Infrastructure - Environmental Quality
Detailed Cost Estimate**



Applicant Name: Metro Link Engineering Ltd.
Project Number: 3
Project Title: Redesign of 16th Avenue/ SW Marine Drive Intersection
Cost Estimate Developed By: Kimia Miraki
Date of Cost Estimate: Monday, April 8, 2024
Cost Estimate Class - A,B,C,D: A

ELIGIBLE COSTS						
	Description	Quantity	Unit	Per Unit Amount		Total Cost
Project Planning						
Community Consultation Plan	Includes: Aboriginal, UBC Residents, Students and staff consultation	1.00	L.S.	\$ 5,000.00		\$ 5,000.00
Construction Staffing Requirement						
Project Director		4.00	Months	\$ 8,000.00		\$ 32,000.00
Project Manager		4.00	Months	\$ 6,500.00		\$ 26,000.00
Project Engineer	Quality control of the construction on behalf of engineering firm and ownership.	2.00	Months	\$ 6,000.00		\$ 12,000.00
Project Coordinator		4.00	Months	\$ 5,000.00		\$ 20,000.00
Superintendent		4.00	Months	\$ 7,000.00		\$ 28,000.00
Foreman		4.00	Months	\$ 4,500.00		\$ 18,000.00
General Requirement Cost						
Traffic Management and Signage	Temporary Signage for traffic management - 2 construction flagger crew	1.00	L.S.	\$ 75,000.00		\$ 75,000.00
Waste Disposal	Construction and demolition waste disposal at the landfill	1.00	L.S.	\$ 90,000.00		\$ 90,000.00
Site Mobilization and Demobilization	Temporary Office for site management crew - Temporary washrooms - Temporary Drainage - Temporary Power	1.00	L.S.	\$ 90,000.00		\$ 90,000.00
Overhead and Fee	8% of total construction cost	1.00	L.S.	\$ 284,411.82		\$ 284,411.82
Planning Sub-Total:						\$ 680,411.82
Design / Engineering						
Geotechnical Assessment	Includes: Assessment of existing subsurface conditions at a project site and Geotechnical analysis of site conditions	1.00	L.S.	\$ 25,000.00		\$ 25,000.00
Environmental Assessment	Includes: Climate lens and permitting & protection	1.00	L.S.	\$ 28,000.00		\$ 28,000.00
Engineering Design	IFC Drawing Package and Specifications	1.00	L.S.	\$ 277,640.00		\$ 277,640.00
Engineering Quality Control	Construction Supervision - Weekly Field Reports	1.00	L.S.	\$ 150,000.00		\$ 150,000.00
Design / Engineering Sub-Total:						\$ 480,640.00
Construction / Materials						
Part A - Roadway						
Excavation		40125.00	m ³	\$ 22.00		\$ 882,750.00
Granular Sub-Base (SGSB)	300 mm depth 25 mm + 75 mm Crush Base Course (CBC) - WGB Placement & Compaction	9399.00	tonne	\$ 10.00		\$ 93,990.00
Crush Base Course (CBC)	300 mm depth Granular Sub-Base (SGSB) - Placement & Compaction	11748.75	tonne	\$ 13.00		\$ 152,733.75
Asphalt	100 mm depth of Hot Mix Asphalt - Supply & Pour	3750.00	sqm	\$ 35.00		\$ 131,250.00
20Mpa Concrete	Side Walk, Curb and Gutter - Supply & Pour	300.00	m ³	\$ 250.00		\$ 75,000.00
Part B - Storm Water Management						
48" Roadside Concrete Block Barrier	For protection of retention tank - Precasted - Supply & Placement	30.00	EA	\$ 500.00		\$ 15,000.00
Retention Tank	865m ³ Stainless Steel Tank	1.00	L.S.	\$ 80,000.00		\$ 80,000.00
Oil/ Grit Separator (OGS)		1.00	L.S.	\$ 50,000.00		\$ 50,000.00
Pipe System	800mm Pipe routing water from catchbasins towards tank - Supply & Install	350.00	m	\$ 20.00		\$ 7,000.00
Surface Soil for Rain Garden	150mm deep	540.00	m ³	\$ 26.00		\$ 14,040.00
Catchbasin	600mm x 600mm Precast Concrete Catchbasin - Supply & Install	4.00	L.S.	\$ 4,500.00		\$ 18,000.00
PVC Catch basin Lead	300mm PVC Lead - Supply & Install	4.00	L.S.	\$ 150.00		\$ 600.00
Part C - Gateway						
Hallow Structural Steel (HSS)	HS254x254x16 - Column x 2 - Supply & Install	26.00	ft	\$ 22.00		\$ 1,144.00
Hallow Structural Steel (HSS)	HSS178x178x16 - Beam x 2 - Supply & Install	70.00	ft	\$ 16.00		\$ 2,240.00
Hallow Structural Steel (HSS)	HSS127x127x13 - Girder x 10 - Supply & Install	10.00	ft	\$ 14.00		\$ 1,400.00
LED Screen	9m LED Sign for Roadway	1.00	LS	\$ 35,000.00		\$ 35,000.00
Solar Pannels	2x 100 W Solar Panel - Supply & Install	2.00	EA	\$ 150.00		\$ 300.00
30Mpa Concrete + 4 15-M Rebar	Gateway Footing - Supply & Install	2.00	L.S.	\$ 600.00		\$ 1,200.00
Part D - Traffic						
Traffic Sign	Roadway Signs as per MOTIS Guide - Supply & Install	10.00	EA	\$ 200.00		\$ 2,000.00
Traffic Signal	Signalized Intersection - Supply & Install - Including BC Hydro PowerLine & Lighting System	3.00	EA	\$ 380,000.00		\$ 1,140,000.00
Light Pole Removal & Install	Removing 14 of the existing light poles and adding 9 new light poles (2 of which are the traffic lights, so total of 7 lights)	1.00	L.S.	\$ 600,000.00		\$ 600,000.00
Roadway Marking	Marking of Newly Constructed Roadways	1.00	L.S.	\$ 1,500.00		\$ 1,500.00
Part E - Misc						
Landscape & Streetscape	Includes: Tree Removal, Deciduous Shade Trees, and Softscape	1.00	L.S.	\$ 40,000.00		\$ 40,000.00
Construction / Materials Sub-Total:						\$ 3,555,147.75
Other Eligible Costs						
Design Allowance	5% According to RAIC	1.00	L.S.	\$ 177,757.39		\$ 177,757.39
Insurance & Bonding for Construction	4% bond per 2020 Standard Specifications for Highway Construction Volume 1 of 2	1.00	L.S.	\$ 142,205.91		\$ 142,205.91
Other Eligible Costs Sub-Total:						\$ 142,205.91
Contingency						
Class A Contingency		1.00	L.S.	\$ 0.12		\$ 426,617.73
Contingency Sub-Total:						\$ 426,617.73
Total Construction & Planning Cost:						\$ 4,804,383.21
TOTAL ELIGIBLE COSTS :						\$ 5,265,923.21
INELIGIBLE COSTS LIST						
Land Acquisition Cost						
Leasing Land, Buildings and Other Facilities						
Financing Charges						
Legal Fees						
In-kind Contribution						
Tax Rebate						
Other						
Cost Estimate Comments						
All estimates were done in accordance to: British Columbia Transportation Project Cost Estimating Link: https://www2.gov.bc.ca/gov/content/transportation/transportation-infrastructure/transportation-planning/cost-estimating . All estimates were checked with Ministry of Transportation and Infrastructure CONSTRUCTION AND REHABILITATION COST GUIDE.						
Cost Estimate Classes - definitions & assumptions (sourced from Association of Professional Engineers and Geoscientists of British Columbia (APEGBC))						
Cost estimate class	Features & Uses				Suggested Contingency for Associated Class	
Class A	Detailed estimate based on final drawings and specifications Used to evaluate tenders				±10-15%	

Appendix D: Site Photographs



Figure 22: Site Photo 1 (March-27-2024)



Figure 23: Site Photo 2 (March-27-2024)



Figure 24: Site Photo 3 (March-27-2024)



Figure 25: Site Photo 4 (March-27-2024)

Appendix E: Roadway Maintenance Plan

Table 9: Roadway Maintenance Plan [11]



Maintenance Category	Maintaining Measures	Maintenance Specification
Surface Maintenance	<p>Asphalt Pavement Maintenance:</p> <p>Surface Treatment:</p> <p>Highway and Shoulder Grading & Reshaping:</p> <p>Surface and Shoulder Graveling:</p> <p>Road Base Maintenance:</p> <p>Surface Cleaning:</p> <p>Debris Removal:</p>	<p>PM1.01.2-1: Routine Maintenance Service (Conduct temporary patches consist with the profile and crossfall of the adjacent surface)</p> <p>PM1.01.3-1: Quantified Maintenance Service (Construct permanent patches consistent with the profile and crossfall of the adjacent surface on Highways and bicycle pathways)</p> <p>PM1.01.3-3: Remove residual coating material within 1 day of cured Crack Sealing or Crack Filling.</p> <p>*Use section 502 of the <u>Standard Specification for Highway Construction</u></p> <p>PM1.01.3-1: Quantified Maintenance Service (Construct surface treatment)</p> <p>PM1.03.3-1: Quantified Maintenance Service (Grading or re-shaping of dirt and gravel)</p> <p>PM1.03.3-2: Quantified Maintenance Service (Shoulder grading)</p> <p>PM1.04.3-1 to 4: Quantified Maintenance Service (Apply dust control and base stabilization on dirt and gravel highway by June 1st of each calendar year. Apply or reapply dust applications within 10 days at areas with deficiencies when required.)</p> <p>PM1.06.3-1: Quantified Maintenance Service (Remove unsuitable materials, provide free drainage, and place granular fill)</p> <p>PM1.07.2-1 to 3: Routine Maintenance Service (Remove accumulation and hard surface highway surface and raised hard surface infrastructure)</p> <p>PM1.08.2-1 & 2: Routine Maintenance Service (Remove debris from highways and railway crossings)</p>
Drainage Maintenance	Ditch Maintenance	<p>PM2.01.2-1: Routine Maintenance Service (Remove debris and obstructions from ditches where heavy equipment is not required and can be undertaken by handwork)</p> <p>PM2.01.3-1: Quantified Maintenance Service (Remove debris and obstructions and re-establish existing ditches or construct new Ditches requiring heavy equipment)</p>

	Drainage Appliance Maintenance	<p>PM2.02.2-1: Routine Maintenance Service (Remove debris and obstructions from ditches where heavy equipment is not required and can be undertaken by handwork)</p> <p>PM2.02.3-1: Quantified Maintenance Service (Remove debris and obstructions affecting the water flow or repair or replace existing drainage appliances, where heavy equipment is required)</p>
Winter Maintenance	<p>Highway Snow Removal</p> <p>Snow and Ice Bonding Prevention & Control</p> <p>Snow Avalanche Response</p>	<p>PM3.01.2-1 to 6: Routine Maintenance Service (Remove winter accumulations from travelled lanes at the end of weather event, remove slush or broken compact from travelled lanes, compact conditions on travelled lanes at all times)</p> <p>PM3.02.2-4 to 6: Routine Maintenance Service (Restore traction on travelled lanes with slippery conditions and during freezing rain, by using chemical elements)</p> <p>PM3.04.2-1 to 4: Routine Maintenance Service (Implement avalanche search and rescue plans immediately upon being notified by the Province and participate in search and rescue efforts, and mobilize required equipment and resources to the pre-staging locations determined by the Province, within 2 hours upon being notified by the province. Commence the removal of snow deposits within 12 hours upon being notified by the province)</p>
Roadside Maintenance	<p>Vegetation Control</p> <p>Bush, Terr and Danger Tree Removal</p> <p>Roadside Catchment Appurtenances Maintenance</p>	<p>PM4.01.3-1 to 3: Quantified Maintenance Service (Cut vegetation that exceeds 15 centimetres)</p> <p>PM4.02.3-1 to 5: Quantified Maintenance Service (completely remove brush/trees along Highways that cause Sight Distance obstructions or impede drainage or create shaded areas on the road surface, and completely remove overhanging trees/limbs over Travelled Lanes and Shoulders)</p> <p>PM4.05.3-1 to 7: Quantified Maintenance Service (replace within 3 months, damaged or deteriorated Roadside Catchment Appurtenances that have not been structurally compromised)</p>
Structure Maintenance	Steel, Aluminum and Multiple Structure Maintenance	PM6.09.2-1 to 4: Routine Maintenance Service (Restrict the load-carrying capacity or vehicle usage or all access to the Structure as directed by the Province, and replace within 3 months, any damaged, deteriorated or missing rivets, bolts and components)
Traffic Maintenance	Sign System Maintenance Temporary Pavement Markings and Eradication	PM5.01.2-1 to 4: Routine Maintenance Service (Maintain Sign Systems so they are clean, repaired, legible, visible, erect, and properly placed)

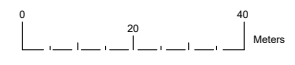

	<p>Traffic Management</p>	<p>PM5.01.3-1 to 5: Quantified Maintenance Service (Install Sign Systems within three days after delivery at new locations, replace barrier and shoulder mounted delineators within 10 days, that are missing or are no longer effective, and install barrier and shoulder mounted delineators within 10 days at new locations.)</p> <p>PM5.02.2-1 to 2: Routine Maintenance Service (Place temporary pavement markings within 3 hours of altered permanent pavement markings by the Contractor)</p> <p>PM5.02.3-1 to 2: Quantified Maintenance Service (Restore temporary pavement markings placed by others and Eradicate pavement markings placed)</p> <p>PM5.03.2-1 to 6: Routine Maintenance Service (Respond immediately to unplanned events or incidents and take appropriate actions to ensure the safety of Highway Users until traffic management and temporary control measures can be deployed, and to any traffic management deficiency, as approved by the Province. Establish traffic management beyond Service Area boundaries at key decision making points when required, to ensure minimum disruption to highway users.)</p>
<p>Network Maintenance</p>	<p>Incident Response</p> <p>Major Event Response</p> <p>Safety Patrol Communications</p>	<p>PM7.01.2-1 to 7: Routine Maintenance Service (Respond immediately to all traffic related incidents in accordance with the Inter-Agency Motor Vehicle Incident Response Strategic Protocol and eliminate potential contaminants immediately, working in cooperation with regulatory agencies, police authorities and the province)</p> <p>PM7.02.2-1 to 2: Routine Maintenance Service (Monitor areas and the Highway infrastructure that are known or suspected of being at risk, before, during and after a major event)</p> <p>PM7.05.2-1 to 3: Routine Maintenance Service (Communicate Highway conditions with all local authorities, Update DriveBC and Communicate with the public and Stakeholders)</p>

Appendix F: Issued for Construction Design Drawings & Specifications

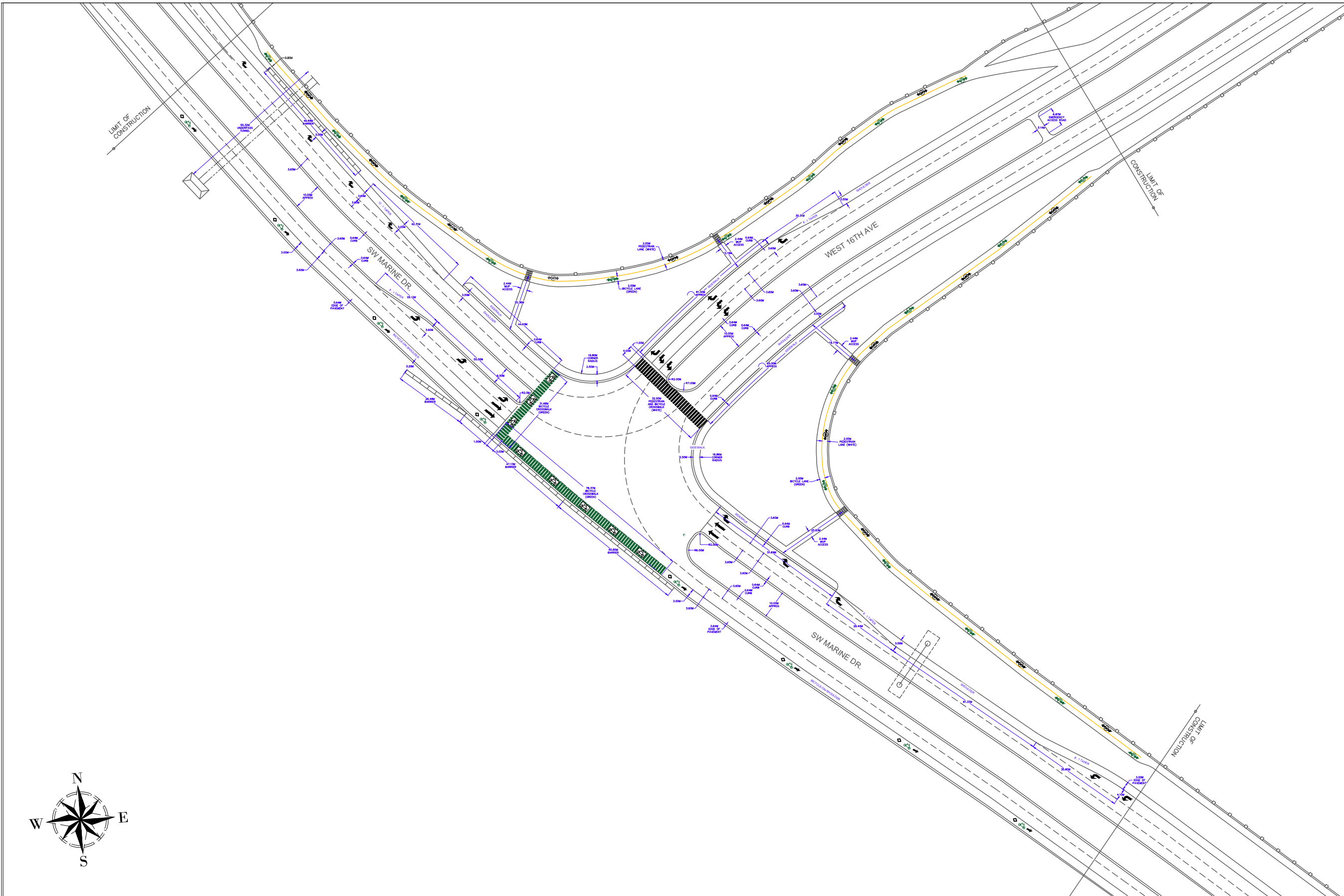

Location SW Marine Dr. & West 16th Ave. University Endowment Lands		
Scale 		
DATE	REV	DESCRIPTION
2024.04.10	0	FOR FINAL REPORT SUB.
Project Redesign of Intersection: SW Marine Dr. & West 16th Ave.		
Client UBC SEEDS Sustainability Program		
		
Date	April 10, 2024	
Drawn	Y. Wang	
Design	N. Dhaliwal Y. Wang	
Checked	K. Miraki	
Sheet Title Overview of Key Design Elements in Planar View		
Drawing No.	SP-01	Revision No. 00
Job No.	00	Sheet No. 01

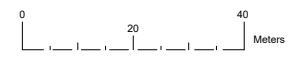

Location SW Marine Dr. & West 16th Ave. University Endowment Lands		
Scale 		
DATE	REV	DESCRIPTION
2024.04.10	1	FOR FINAL REPORT SUB.
2023.12.12	0	FOR PRELIM REP SUB.
Project Redesign of Intersection: SW Marine Dr. & West 16th Ave.		
Client UBC SEEDS Sustainability Program		
		
Date	April 10, 2024	
Drawn	Y. Wang	
Design	N. Dhaliwal Y. Wang	
Checked	K. Miraki	
Sheet Title Planar Dimensions and Pavement Markings		
Drawing No.	Revision No.	
SP-02	01	
Job No. 01	Sheet No. 02	

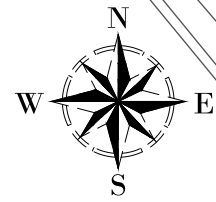

LIMIT OF CONSTRUCTION

LEGEND

- MAINTAIN EXISTING UTILITY
- REMOVE EXISTING UTILITY
- INSTALL NEW STREETLIGHT
- INSTALL NEW SIGNAL & STREETLIGHT
- EXISTING ELECTRICAL BOXES
- TREE CLEARING

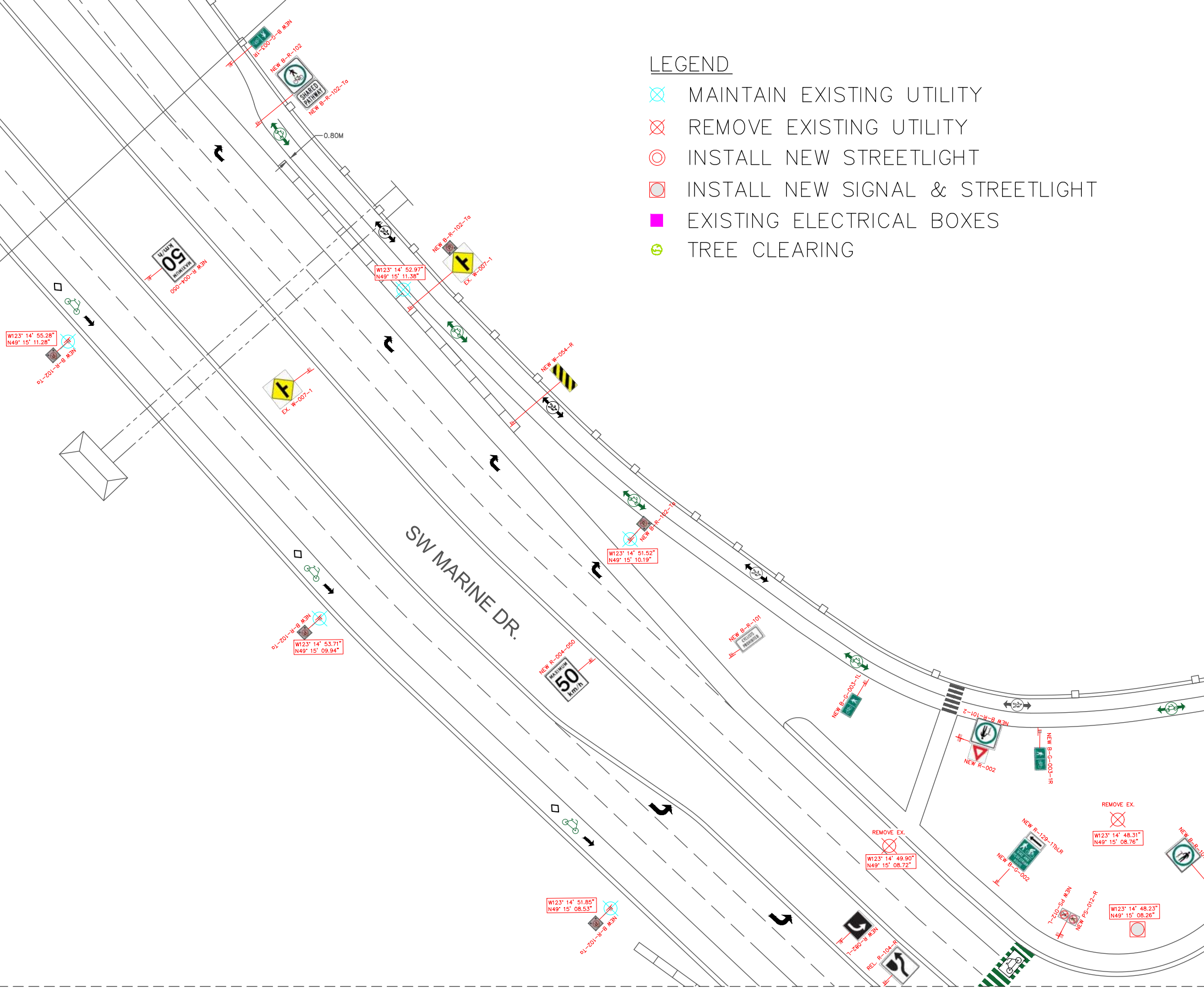

Location SW Marine Dr. & West 16th Ave. University Endowment Lands		
Scale 		
DATE	REV	DESCRIPTION
2024.04.10	1	FOR FINAL REPORT SUB.
2023.12.12	0	FOR PRELIM REP SUB.
Project Redesign of Intersection: SW Marine Dr. & West 16th Ave.		
Client UBC SEEDS Sustainability Program		
Date	April 10, 2024	
Drawn	Y. Wang	
Design	D. Mundi Y. Wang	
Checked	K. Miraki	
Sheet Title Traffic Signage, Utility Plan, and Tree Clearing		
Drawing No.	SP-03	Revision No. 01
Job No.	01	Sheet No. 03

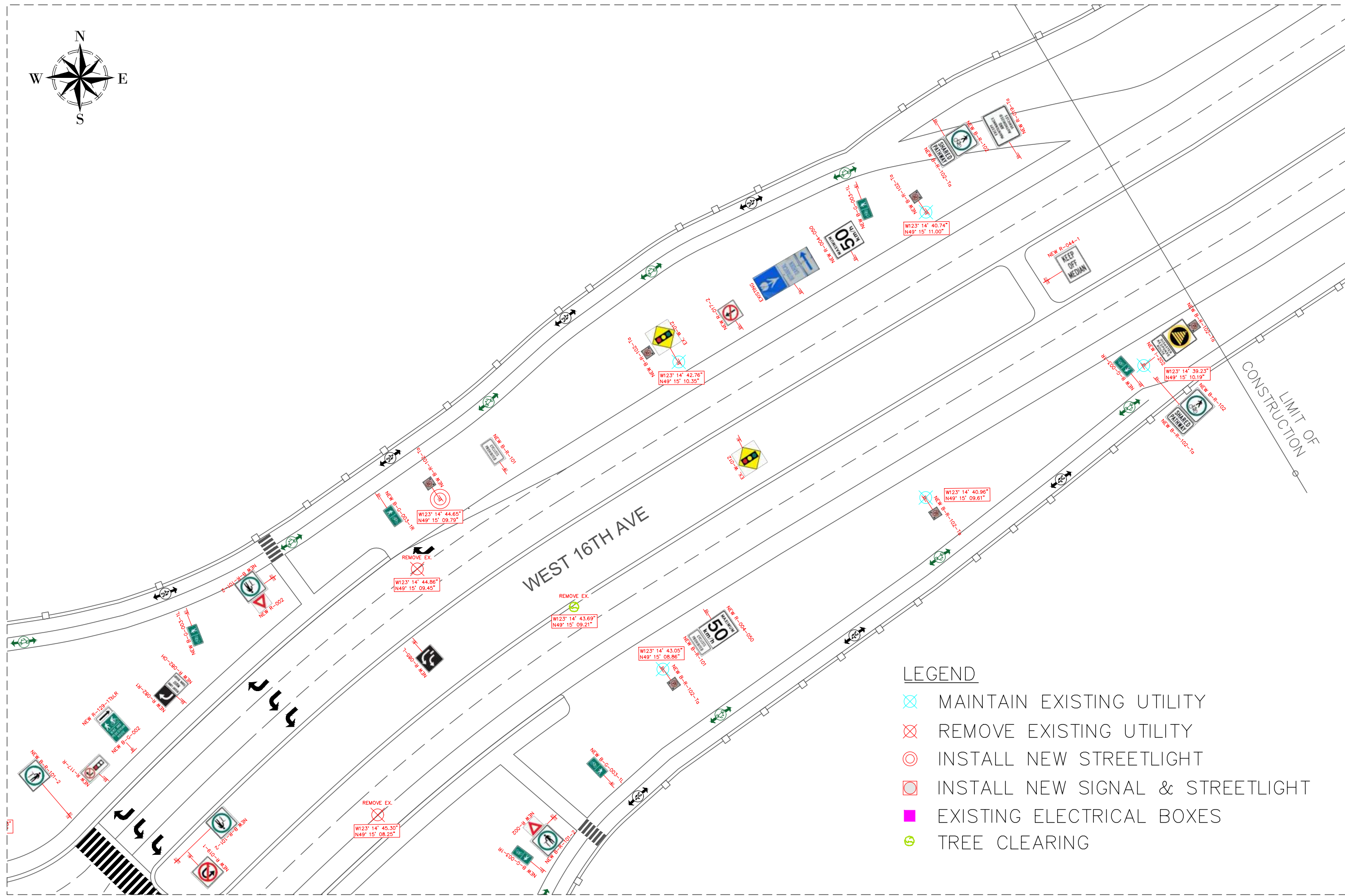
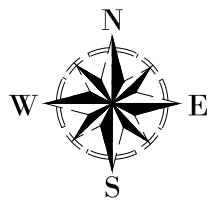

LEGEND

- MAINTAIN EXISTING UTILITY
- REMOVE EXISTING UTILITY
- INSTALL NEW STREETLIGHT
- INSTALL NEW SIGNAL & STREETLIGHT
- EXISTING ELECTRICAL BOXES
- TREE CLEARING

Location SW Marine Dr. & West 16th Ave. University Endowment Lands		
Scale 		
DATE	REV	DESCRIPTION
2024.04.10	1	FOR FINAL REPORT SUB.
2023.12.12	0	FOR PRELIM REP SUB.
Project Redesign of Intersection: SW Marine Dr. & West 16th Ave.		
Client UBC SEEDS Sustainability Program		
Date	April 10, 2024	
Drawn	Y. Wang	
Design	D. Mundi Y. Wang	
Checked	K. Miraki	
Sheet Title Traffic Signage, Utility Plan, and Tree Clearing		
Drawing No.	Revision No.	
SP-04	01	
Job No.	Sheet No.	
01	04	

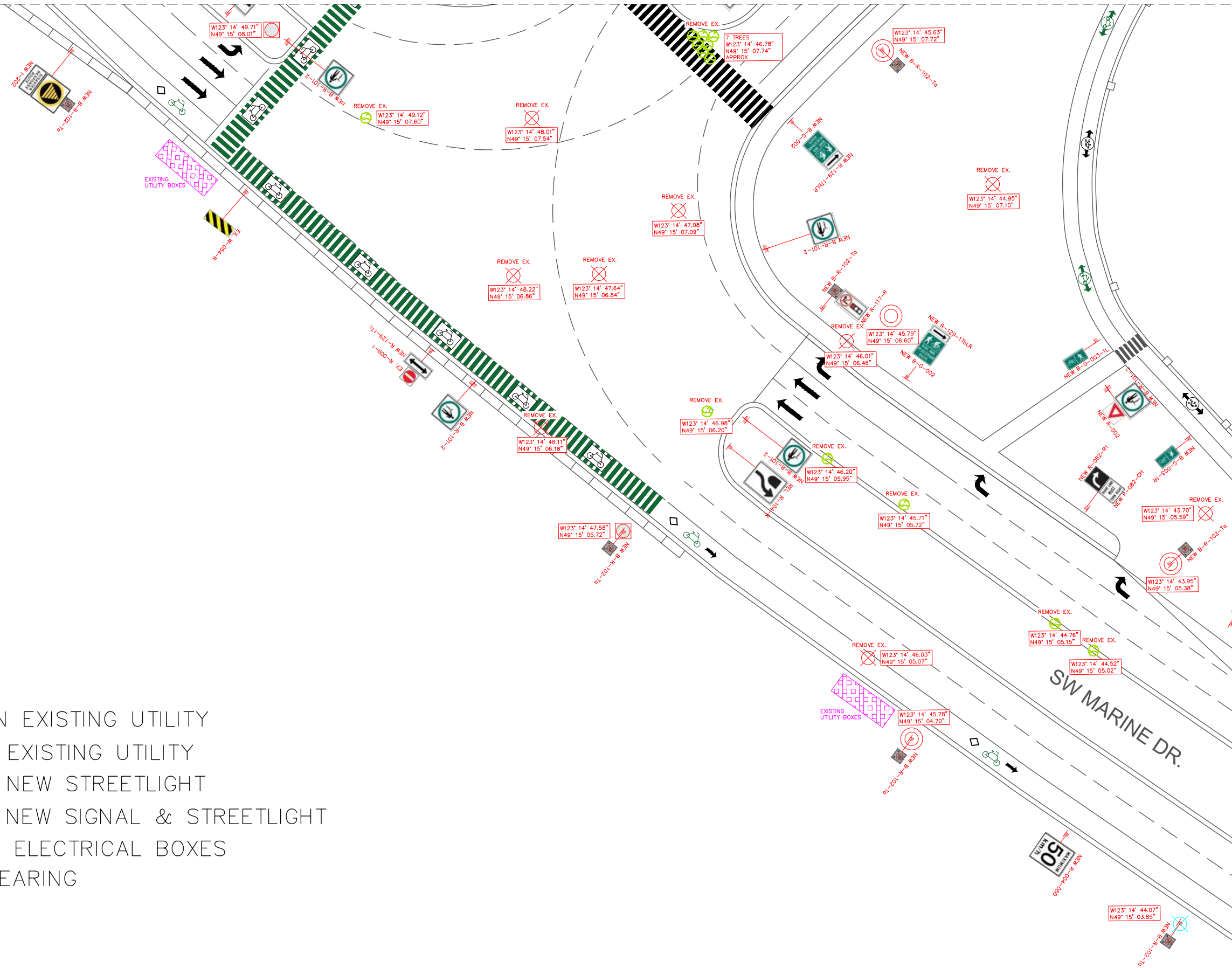
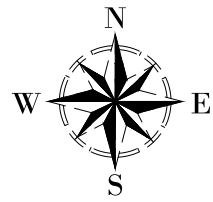

LEGEND

- MAINTAIN EXISTING UTILITY
- REMOVE EXISTING UTILITY
- INSTALL NEW STREETLIGHT
- INSTALL NEW SIGNAL & STREETLIGHT
- EXISTING ELECTRICAL BOXES
- TREE CLEARING

Location SW Marine Dr. & West 16th Ave. University Endowment Lands		
Scale 		
DATE	REV	DESCRIPTION
2024.04.10	1	FOR FINAL REPORT SUB.
2023.12.12	0	FOR PRELIM REP SUB.
Project Redesign of Intersection: SW Marine Dr. & West 16th Ave.		
Client UBC SEEDS Sustainability Program		
Date	April 10, 2024	
Drawn	Y. Wang	
Design	D. Mundi Y. Wang	
Checked	K. Miraki	
Sheet Title Traffic Signage, Utility Plan, and Tree Clearing		
Drawing No.	SP-05	Revision No. 01
Job No.	01	Sheet No. 05

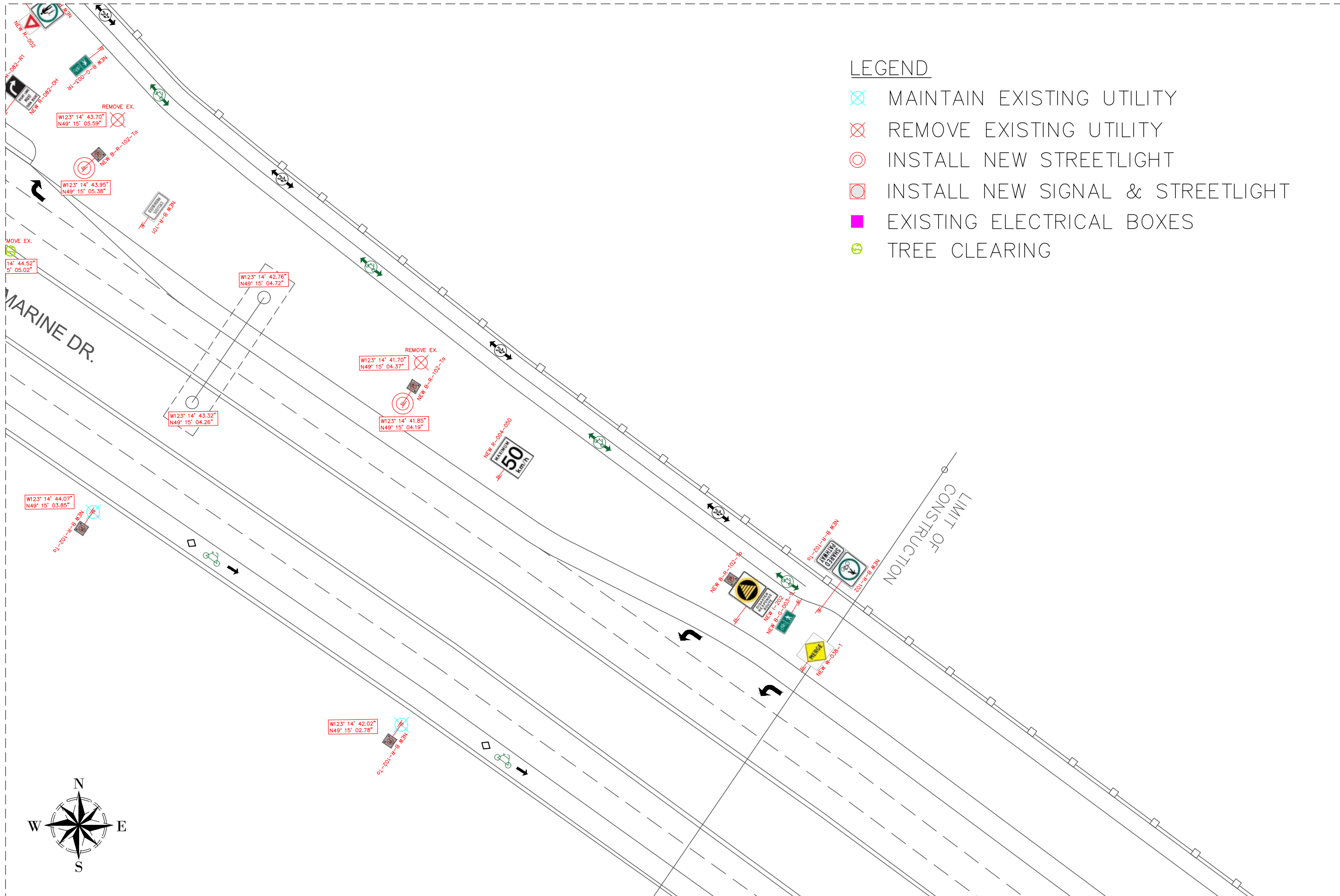

LEGEND

- MAINTAIN EXISTING UTILITY
- REMOVE EXISTING UTILITY
- INSTALL NEW STREETLIGHT
- INSTALL NEW SIGNAL & STREETLIGHT
- EXISTING ELECTRICAL BOXES
- TREE CLEARING

Location
 SW Marine Dr. & West 16th Ave.
 University Endowment Lands

Scale

DATE	REV	DESCRIPTION
2024.04.10	1	FOR FINAL REPORT SUB.
2023.12.12	0	FOR PRELIM REP SUB.

Project
 Redesign of Intersection:
 SW Marine Dr. & West 16th Ave.

Client
 UBC SEEDS Sustainability Program



Date April 10, 2024
Drawn Y. Wang
Design D. Mundi Y. Wang
Checked K. Miraki

Sheet Title
 Traffic Signage,
 Utility Plan, and
 Tree Clearing

Drawing No. SP-06	Revision No. 01
Job No. 01	Sheet No. 06

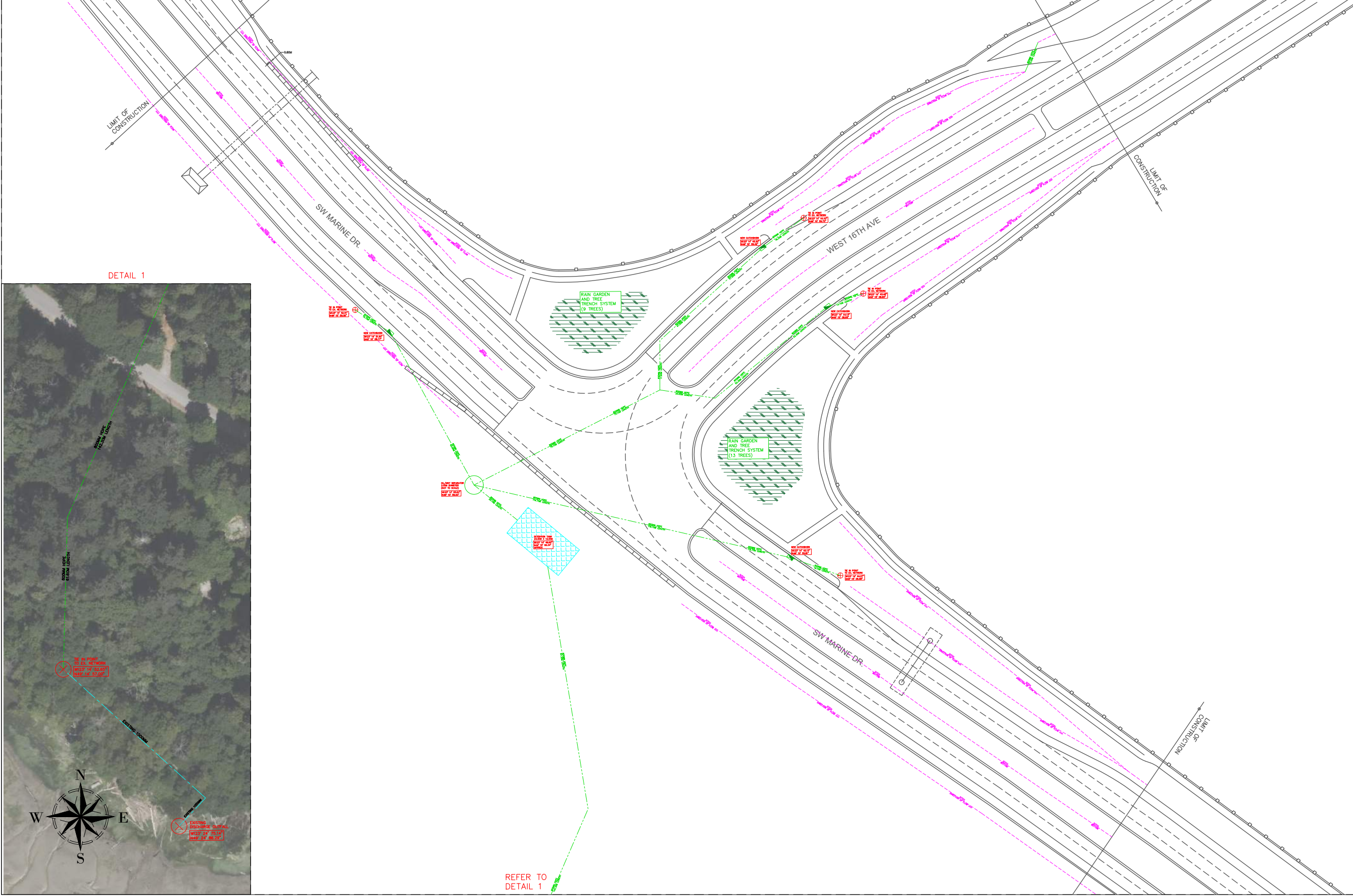

Location SW Marine Dr. & West 16th Ave. University Endowment Lands		
Scale PLAN VIEW DETAIL 1		
DATE	REV	DESCRIPTION
2024.04.10	1	FOR FINAL REPORT SUB.
2023.12.12	0	FOR PRELIM REP SUB.
Project Redesign of Intersection: SW Marine Dr. & West 16th Ave.		
Client UBC SEEDS Sustainability Program		
Date	April 10, 2024	
Drawn	Y. Wang	
Design	C. Sital	
Checked	K. Miraki	
Sheet Title Stormwater, Environmental, and Drainage Plans		
Drawing No.	Revision No.	
SP-05	01	
Job No.	Sheet No.	
01	05	

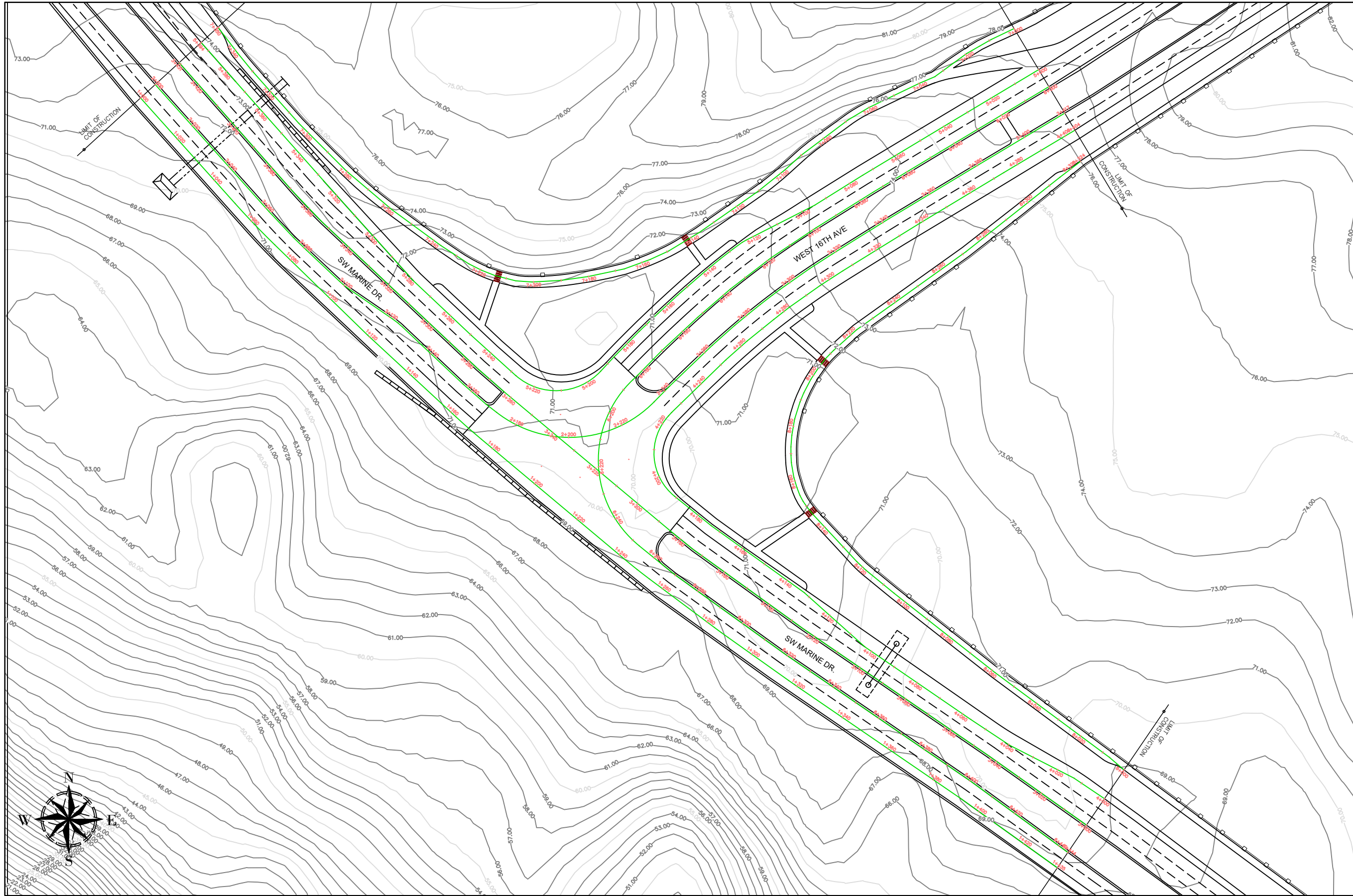

Location		SW Marine Dr. & West 16th Ave. University Endowment Lands	
Scale			
2024.04.10	1	FOR FINAL REPORT SUB.	
2023.12.12	0	FOR PRELIM REP SUB.	
Project			
Redesign of Intersection: SW Marine Dr. & West 16th Ave.			
Client			
UBC SEEDS Sustainability Program			
Date		April 10, 2024	
Drawn		Y. Wang	
Design		Y. Wang	
Checked		K. Miraki	
Sheet Title			
Proposed Horizontal Alignments Over Existing Surface Elevation Contours			
Drawing No.		Revision No.	
SP-08		01	
Job No.		Sheet No.	
01		08	

HORIZONTAL SCALE: 1000
VERTICAL EXAGGERATION (H/V): 10

ALIGNMENT 1 + 00 PROFILE

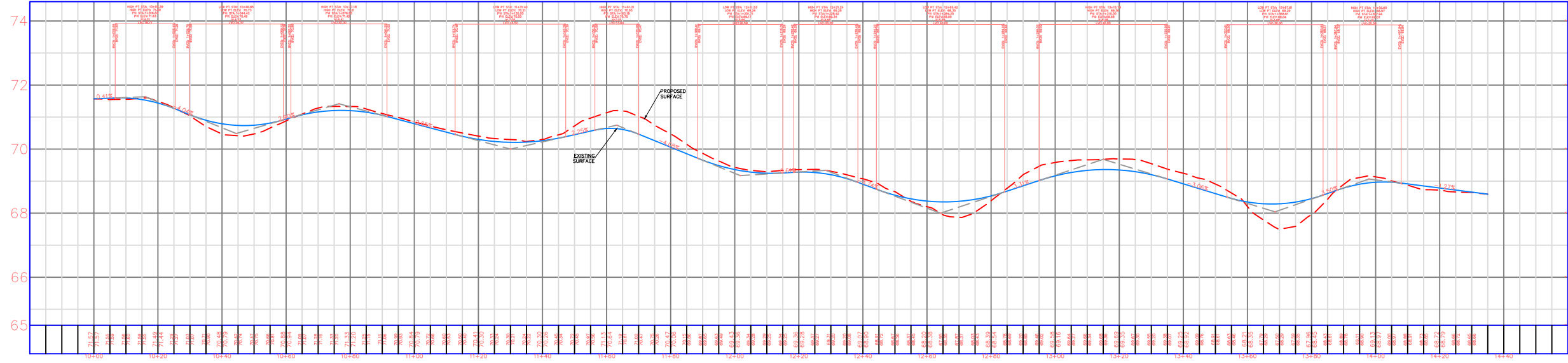

HORIZONTAL SCALE: 1000
VERTICAL EXAGGERATION (H/V): 10

ALIGNMENT 2 + 00 PROFILE

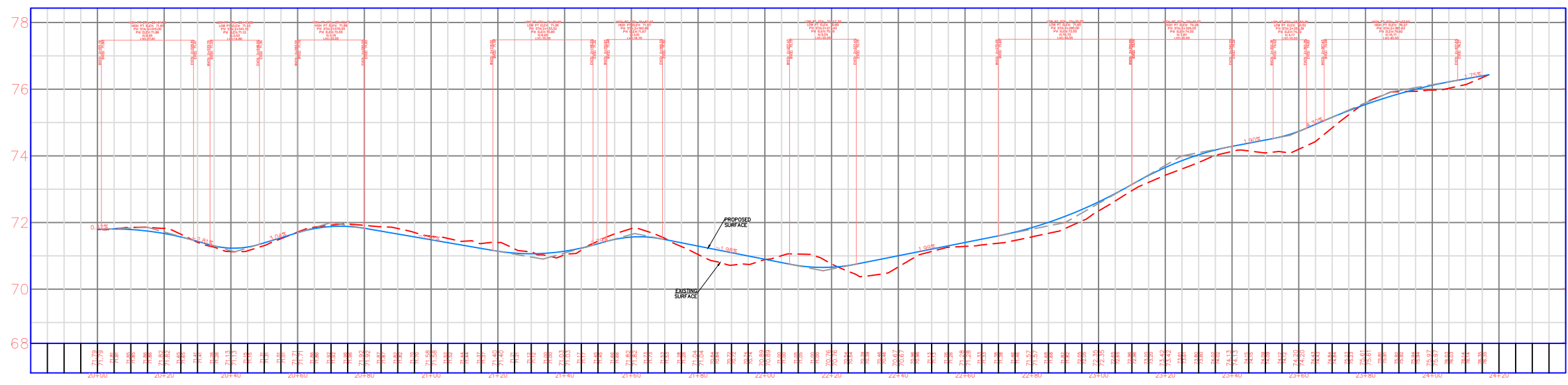

Location SW Marine Dr. & West 16th Ave. University Endowment Lands		
Scale VARIES		
2024.04.10	1	FOR FINAL REPORT SUB.
2023.12.12	0	FOR PRELIM REP SUB.
Project Redesign of Intersection: SW Marine Dr. & West 16th Ave.		
Client UBC SEEDS Sustainability Program		
		
Date	April 10, 2024	
Drawn	Y. Wang	
Design	Y. Wang	
Checked	K. Miraki	
Sheet Title Existing Surface Profile and Proposed Vertical Alignment of 1+00 and 2+00		
Drawing No.	SP-09	Revision No. 01
Job No.	01	Sheet No. 09

HORIZONTAL SCALE: 1000
 VERTICAL EXAGGERATION (H/V): 10

ALIGNMENT 3 + 00 PROFILE

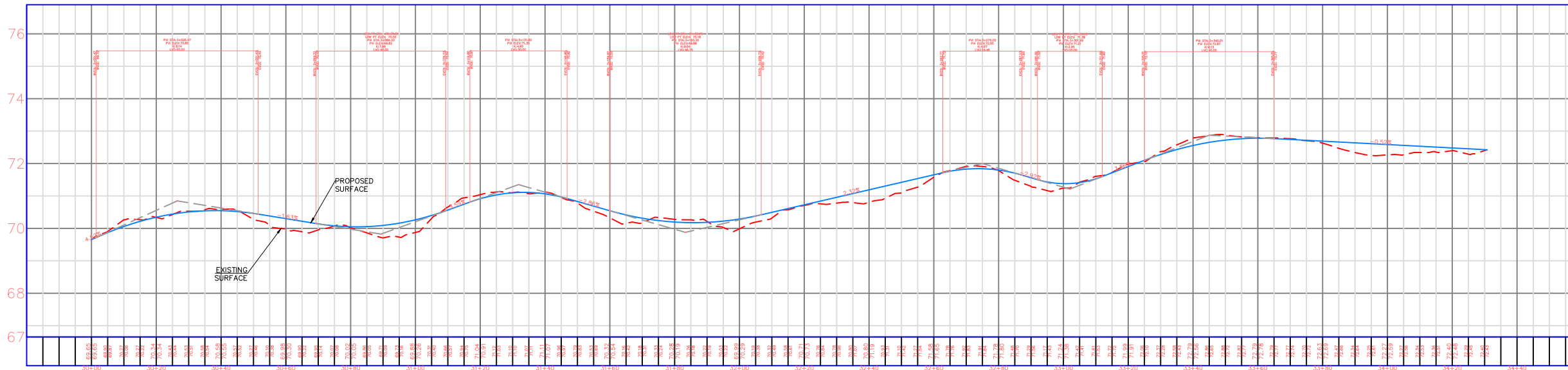

HORIZONTAL SCALE: 100
 VERTICAL EXAGGERATION (H/V): 10

ALIGNMENT 4 + 00 PROFILE

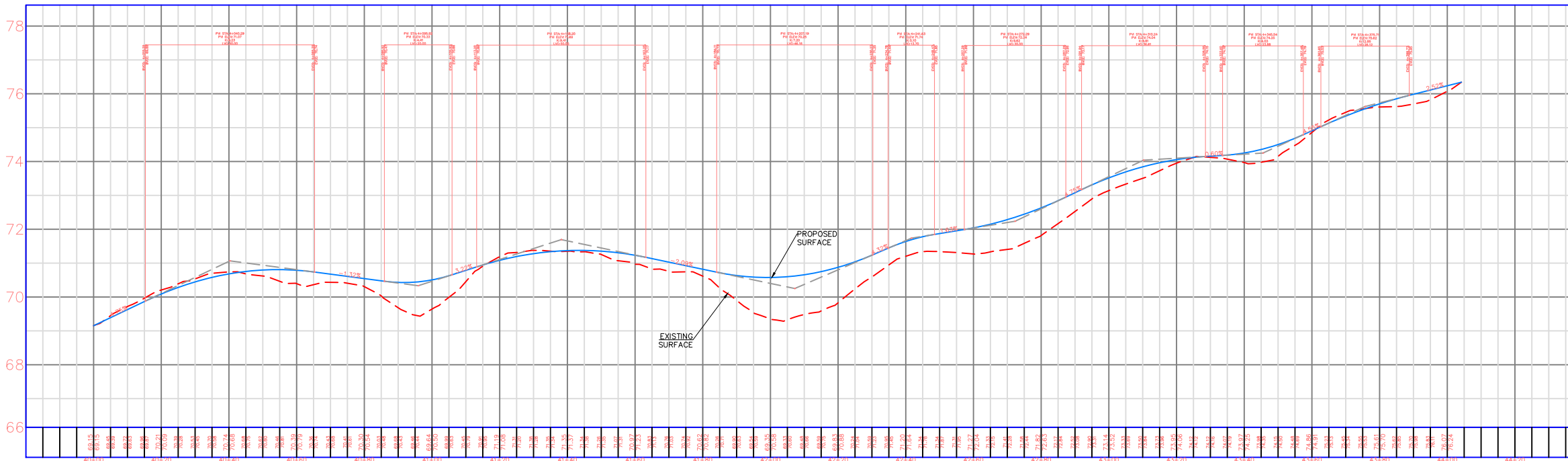

Location
 SW Marine Dr. & West 16th Ave.
 University Endowment Lands

Scale
 VARIES

2024.04.10	1	FOR FINAL REPORT SUB.
2023.12.12	0	FOR PRELIM REP SUB.

Project
 Redesign of Intersection:
 SW Marine Dr. &
 West 16th Ave.

Client
 UBC SEEDS Sustainability Program



Date	April 10, 2024
Drawn	Y. Wang
Design	Y. Wang
Checked	K. Miraki

Sheet Title
 Existing Surface
 Profile and Proposed
 Vertical Alignment
 of 3+00 and 4+00

Drawing No.	SP-10	Revision No.	01
Job No.	01	Sheet No.	10

Location
SW Marine Dr. & West 16th Ave.
University Endowment Lands

Scale
VARIES

2024.04.10	1	FOR FINAL REPORT SUB.
2023.12.12	0	FOR PRELIM REP SUB.

Project
Redesign of Intersection:
SW Marine Dr. &
West 16th Ave.

Client
UBC SEEDS Sustainability Program



Date	April 10, 2024
Drawn	Y. Wang
Design	Y. Wang
Checked	K. Miraki

Sheet Title
Existing Surface
Profile and Proposed
Vertical Alignment
of 5+00 and 6+00

Drawing No.	SP-11	Revision No.	01
Job No.	01	Sheet No.	11

HORIZONTAL SCALE: 1000
VERTICAL EXAGGERATION (H/V): 10

ALIGNMENT 5 + 00 PROFILE

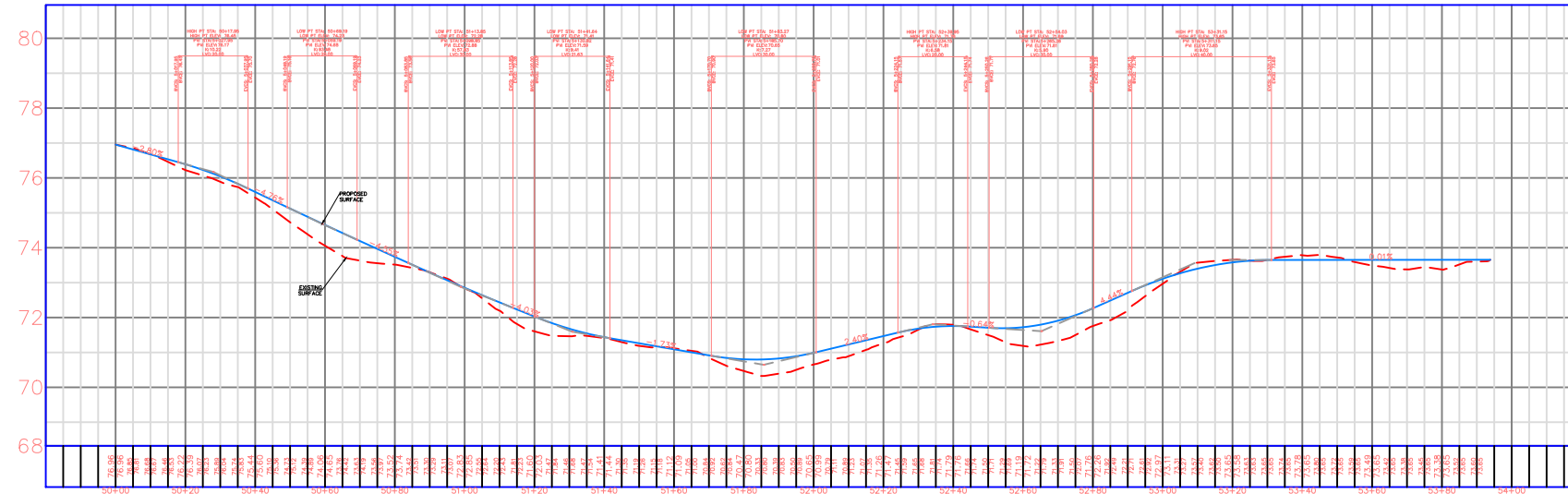

HORIZONTAL SCALE: 1000
VERTICAL EXAGGERATION (H/V): 10

ALIGNMENT 6 + 00 PROFILE

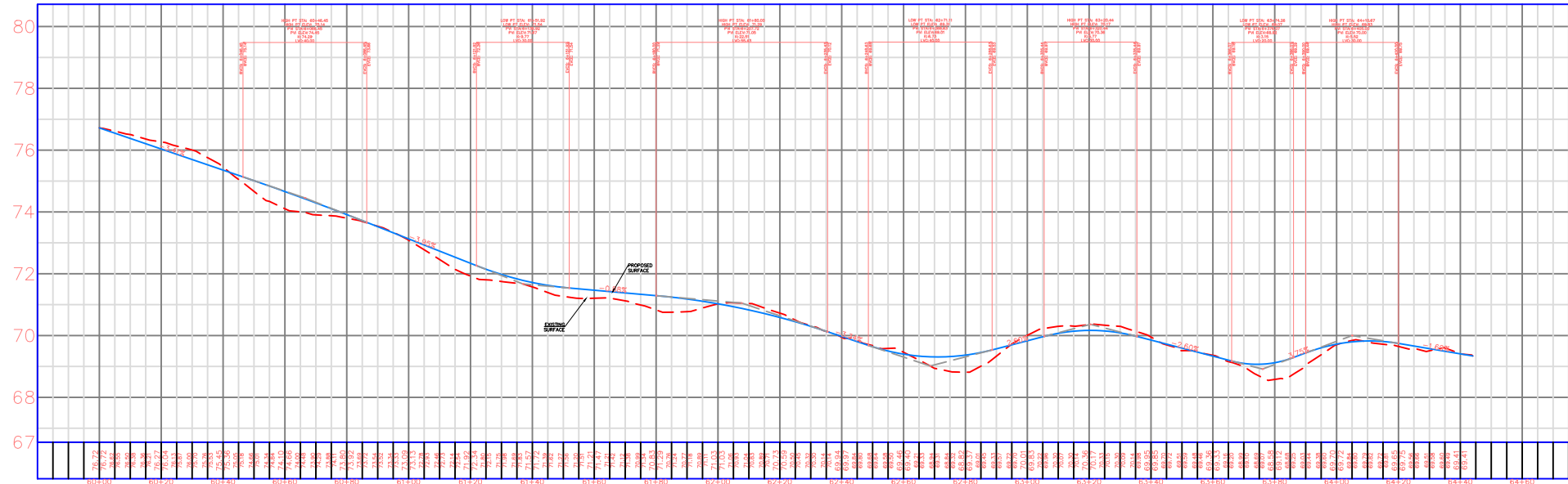

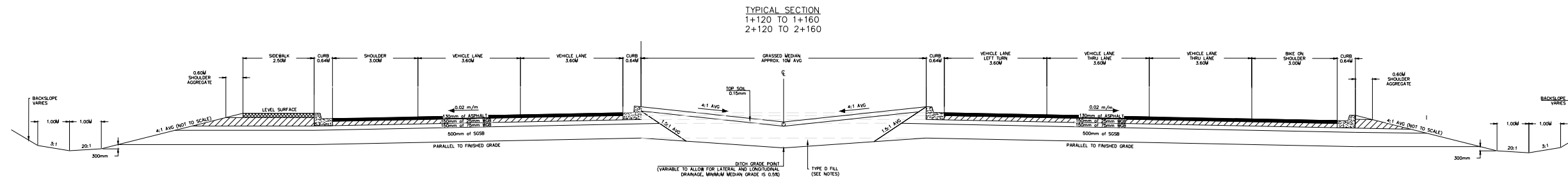
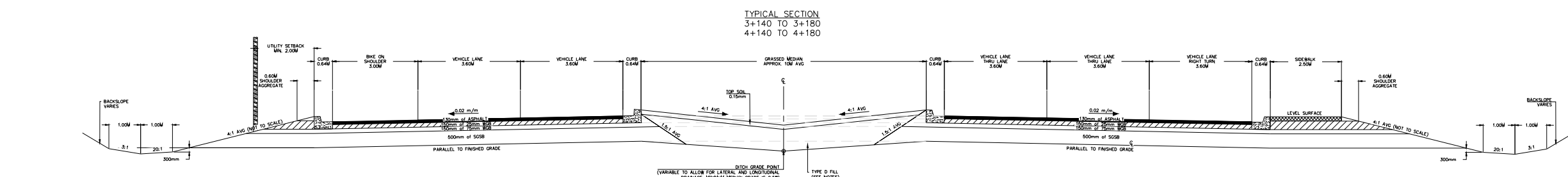
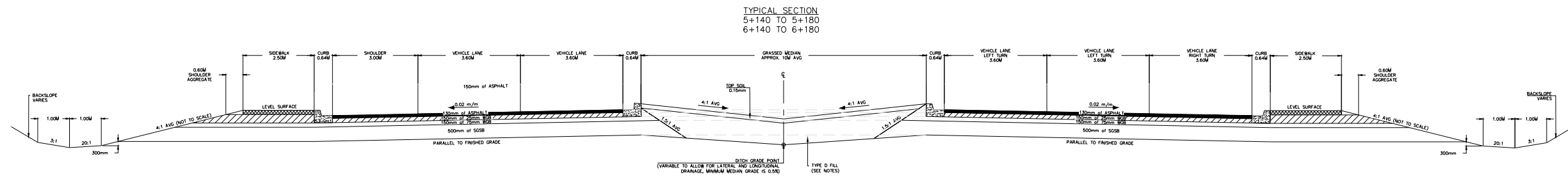

ABBREVIATIONS:
 AP (Asphalt Pavement)
 SGSB (Select Granular Sub-Base)
 WGB (Well Graded Base)

NOTE: TYPE D FILL IS ANY MATERIAL NOT CLASSIFIED AS SOLID FORMATIONS, MASSES, SEAMS OR LAYERS OF DENSE SEDIMENTARY, IGNEOUS, OR METAMORPHIC MATERIAL OF SUFFICIENT HARDNESS REQUIRING DRILLING AND BLASTING METHODS

Location
 SW Marine Dr. & West 16th Ave.
 University Endowment Lands

Scale
 VARIES

2024.04.10	1	FOR FINAL REPORT SUB.
2023.12.12	0	FOR PRELIM REP SUB.

Project
 Redesign of Intersection:
 SW Marine Dr. & West 16th Ave.

Client
 UBC SEEDS Sustainability Program



Date	April 10, 2024
Drawn	Y. Wang
Design	Y. Wang
Checked	K. Miraki

Sheet Title
 Typical Cross Sections

Drawing No.	SP-12	Revision No.	01
Job No.	01	Sheet No.	12

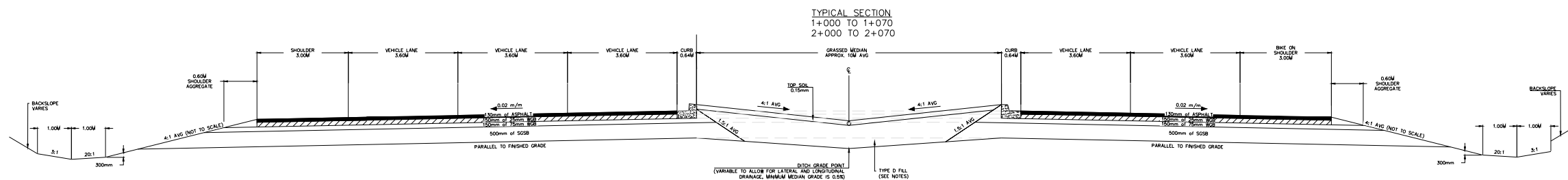
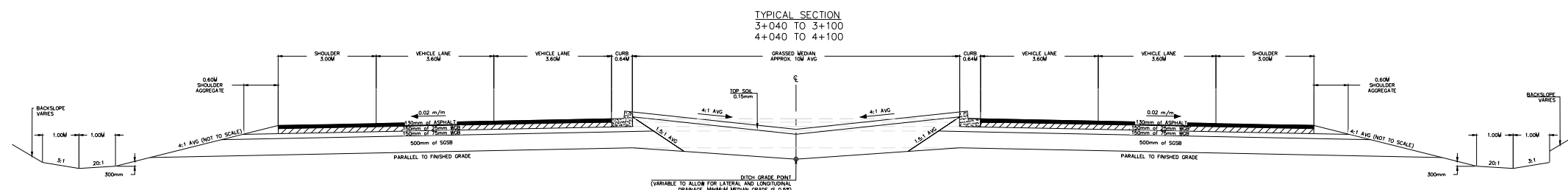
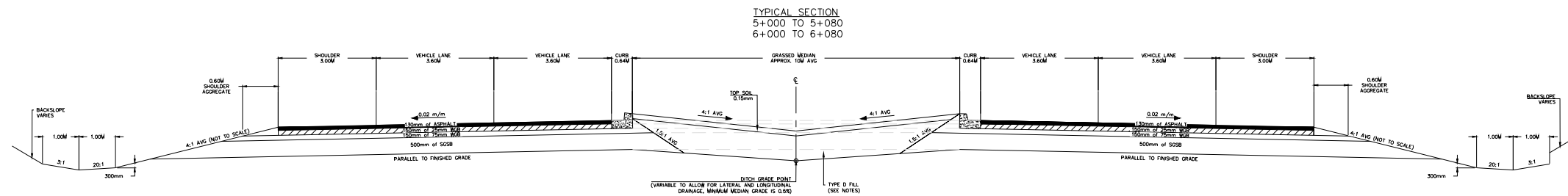

ABBREVIATIONS:
 AP (Asphalt Pavement)
 SGSB (Select Granular Sub-Base)
 WGB (Well Graded Base)

NOTE: TYPE D FILL IS ANY MATERIAL NOT CLASSIFIED AS SOLID FORMATIONS, MASSES, SEAMS OR LAYERS OF DENSE SEDIMENTARY, IGNEOUS, OR METAMORPHIC MATERIAL OF SUFFICIENT HARDNESS REQUIRING DRILLING AND BLASTING METHODS

Location
 SW Marine Dr. & West 16th Ave.
 University Endowment Lands

Scale
 VARIES

2024.04.10	1	FOR FINAL REPORT SUB.
2023.12.12	0	FOR PRELIM REP SUB.

Project
 Redesign of Intersection:
 SW Marine Dr. & West 16th Ave.

Client
 UBC SEEDS Sustainability Program



Date	April 10, 2024
Drawn	Y. Wang
Design	Y. Wang
Checked	K. Miraki

Sheet Title
 Typical Cross Sections

Drawing No.	SP-13	Revision No.	01
Job No.	01	Sheet No.	13

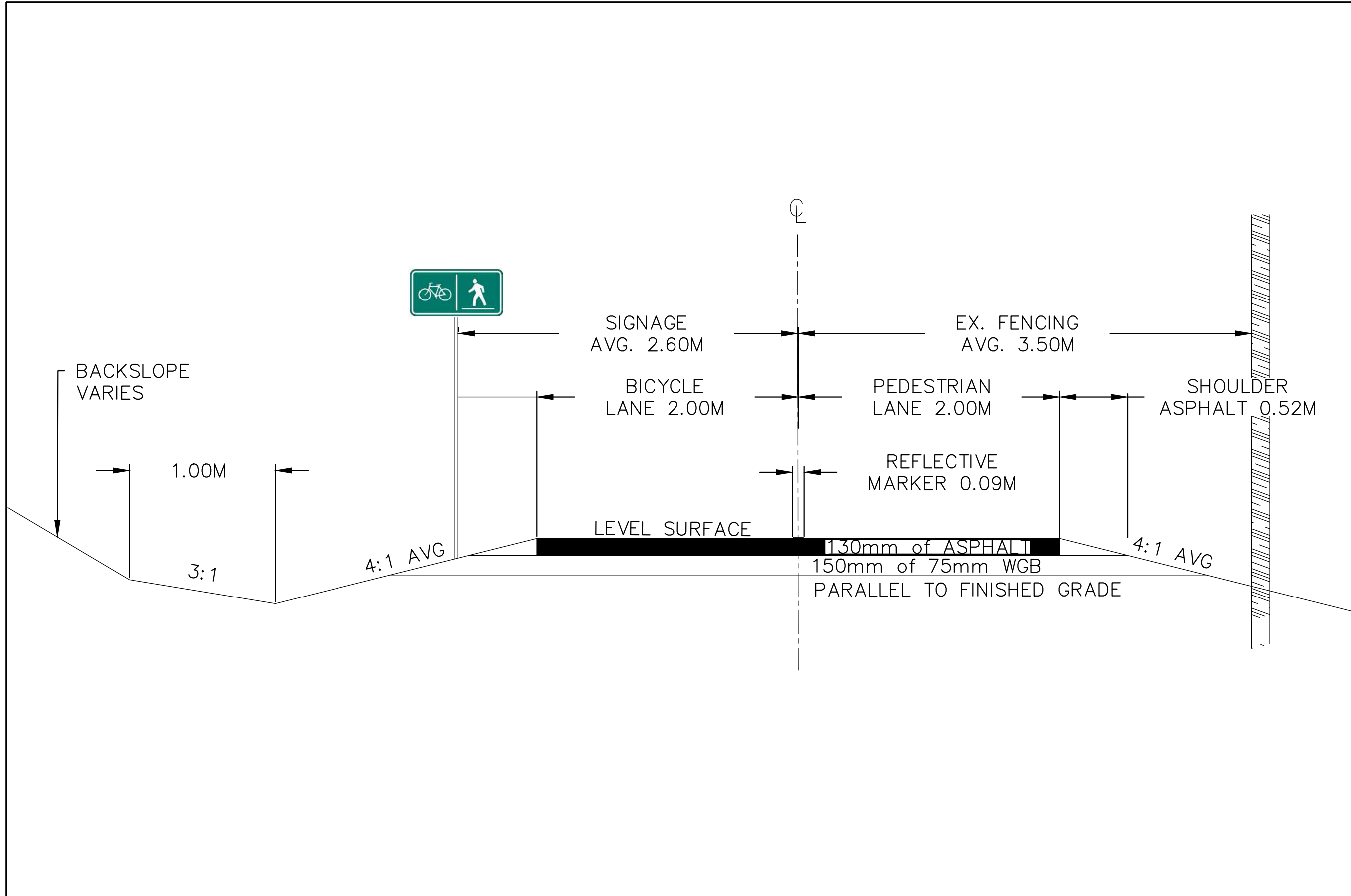

Location	
SW Marine Dr. & West 16th Ave. University Endowment Lands	
Scale	
VARIES	
2024.04.10	0 FOR DETAILED REP SUB.
Project	
Redesign of Intersection: SW Marine Dr. & West 16th Ave.	
Client	
UBC SEEDS Sustainability Program	
	
Date	April 10, 2024
Drawn	Y. Wang
Design	Y. Wang
Checked	K. Miraki
Sheet Title	
Multi-Use Pathway, Typical Cross Section	
Drawing No.	Revision No.
SP-14	00
Job No. 00	Sheet No. 14

ALL MEASUREMENTS UNITS IN MM

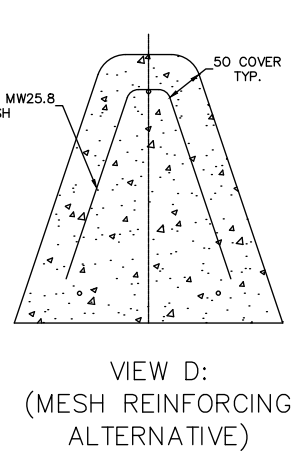
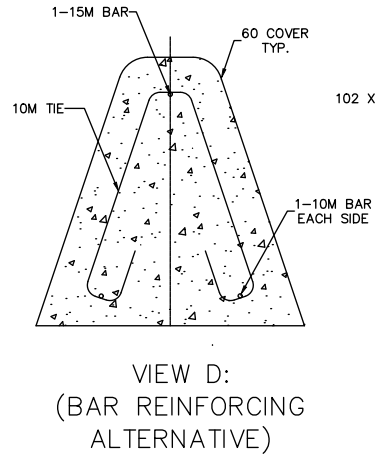
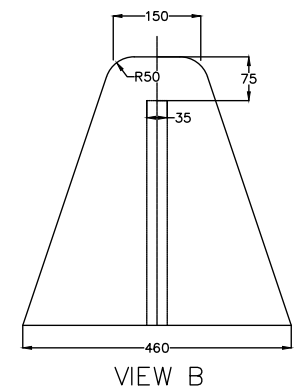
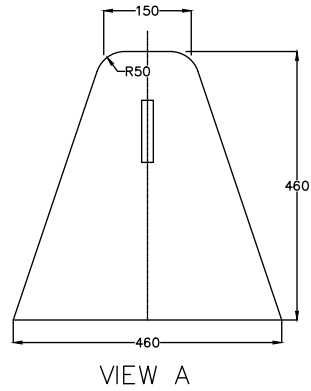
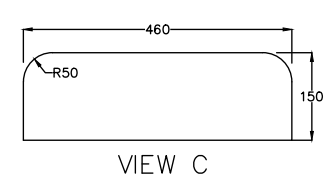
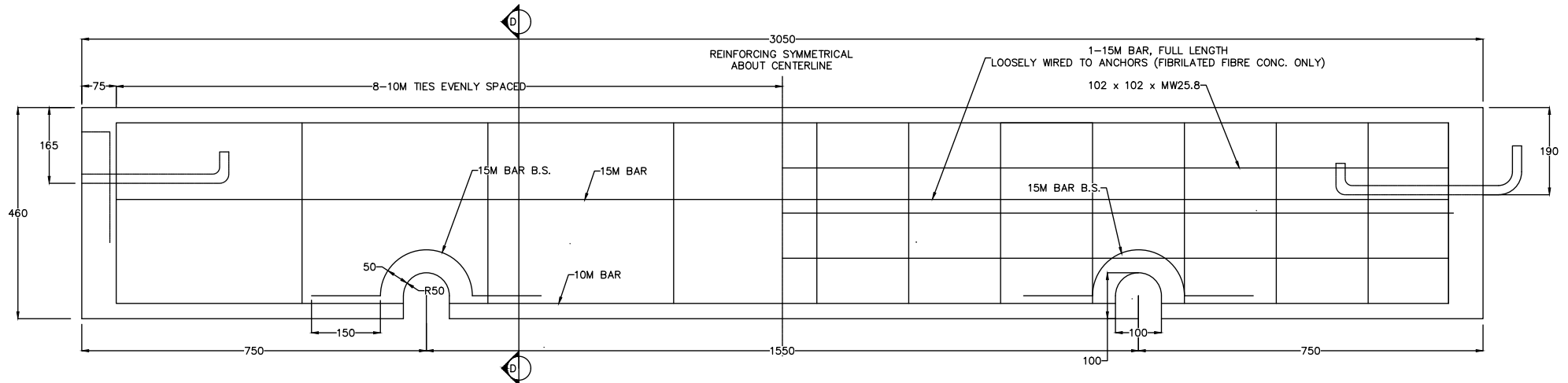
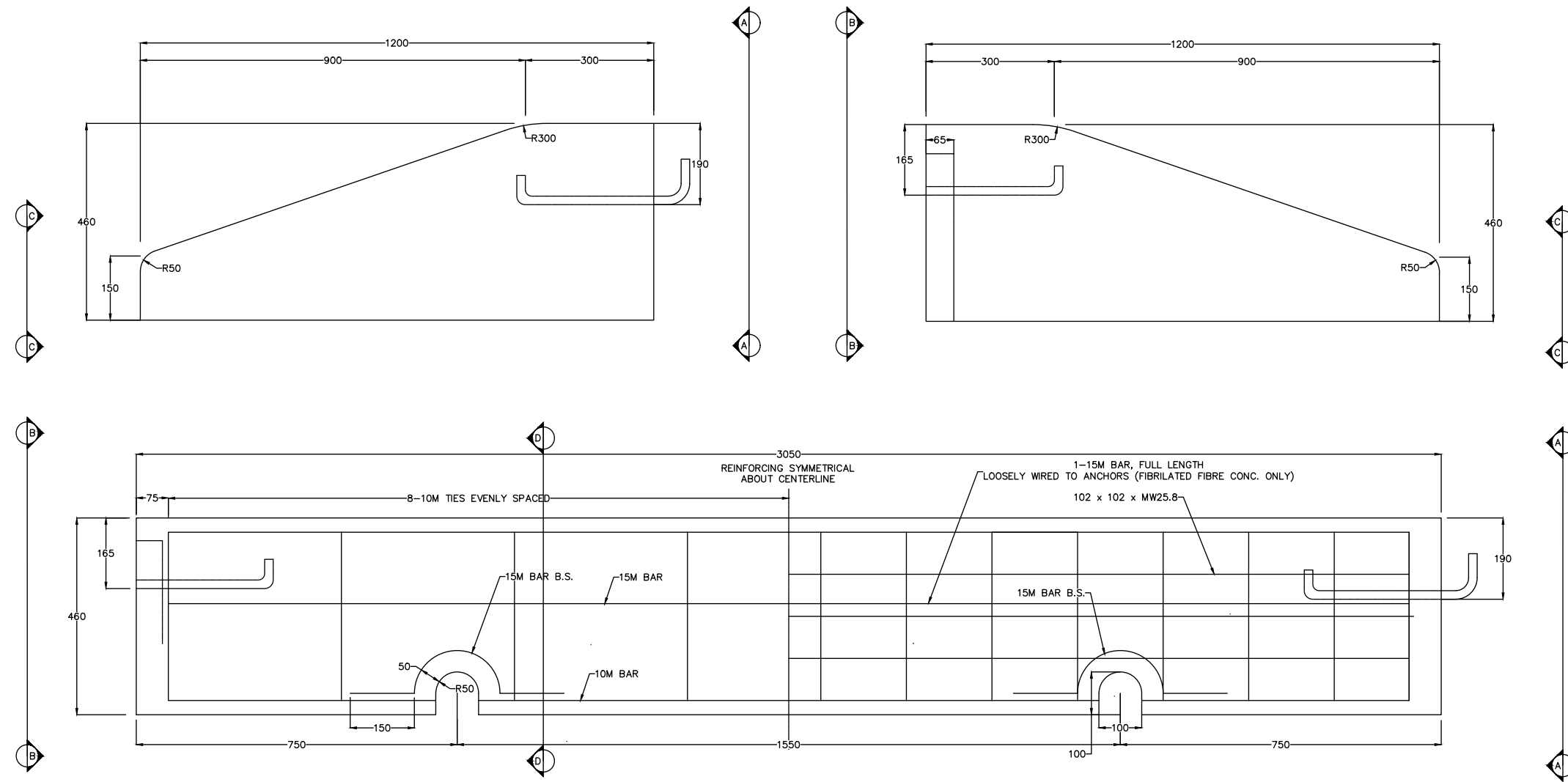

Location SW Marine Dr. & West 16th Ave. University Endowment Lands	
Scale 0 200 400 MM	
2024.04.10 0 FOR DETAILED REP SUB.	
Project Redesign of Intersection: SW Marine Dr. & West 16th Ave.	
Client UBC SEEDS Sustainability Program	
	
Date April 10, 2024	
Drawn Y. Wang	
Design Y. Wang	
Checked K. Miraki	
Sheet Title Roadside Barriers	
Drawing No. SP-15	Revision No. 00
Job No. 00	Sheet No. 15

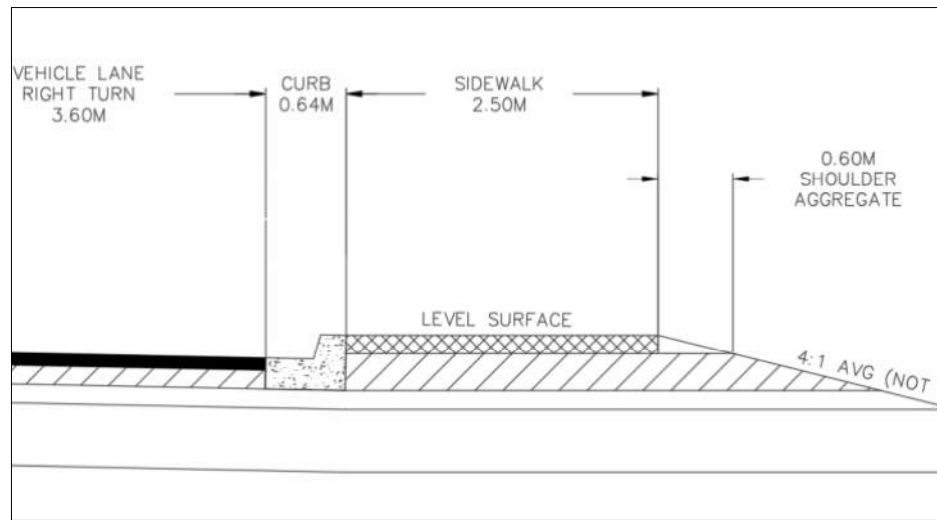

ALL MEASUREMENTS UNITS IN MM
UNLESS OTHERWISE STATED

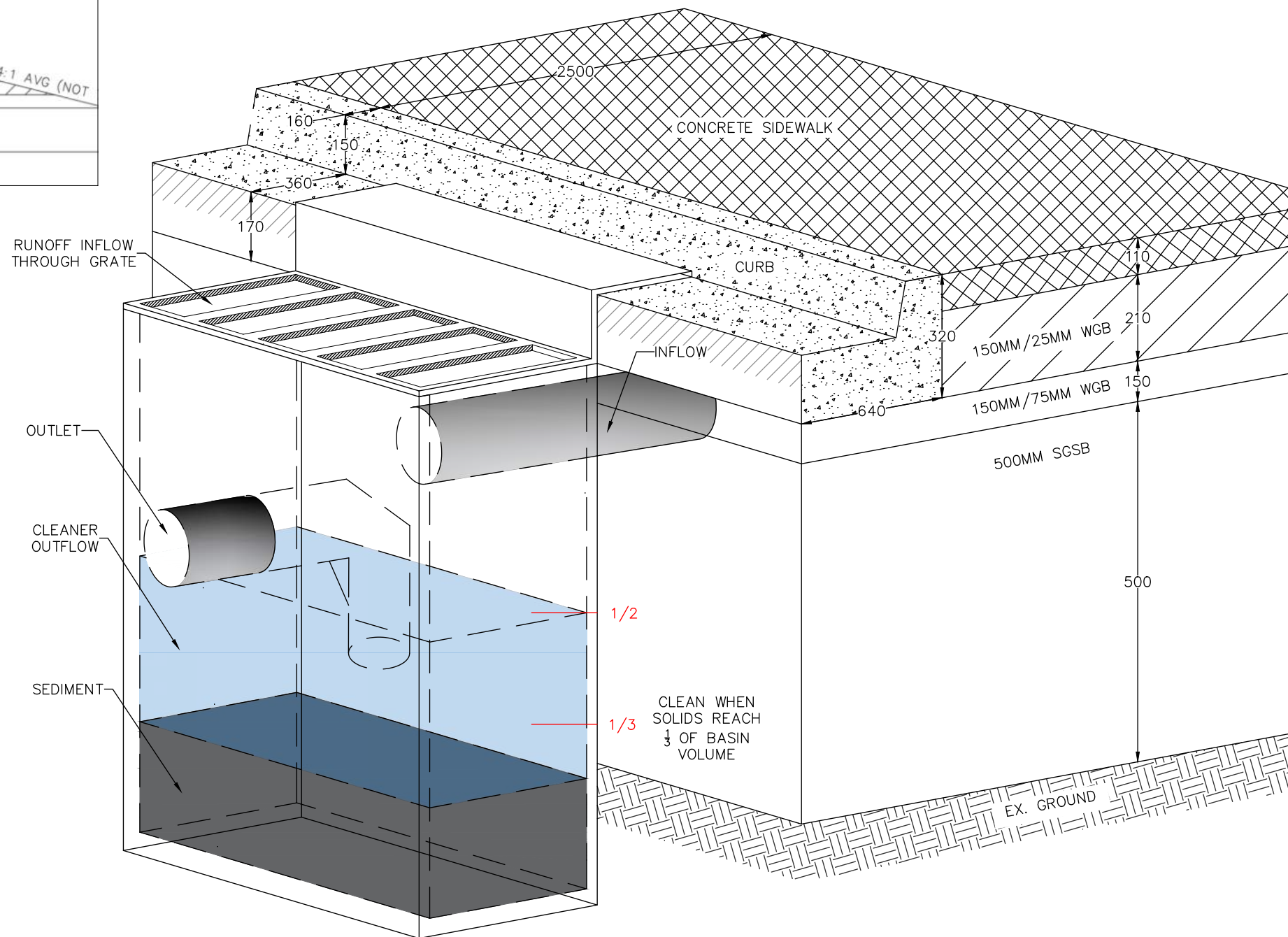

Location SW Marine Dr. & West 16th Ave. University Endowment Lands	
Scale 0 150 300 MM	
2024.04.10	0 FOR DETAILED REP SUB.
Project Redesign of Intersection: SW Marine Dr. & West 16th Ave.	
Client UBC SEEDS Sustainability Program	
	
Date April 10, 2024	
Drawn Y. Wang	
Design G. Sital Y. Wang	
Checked K. Miraki	
Sheet Title Catchbasin, Curb, Sidewalk, and Subgrade Design	
Drawing No. SP-16	Revision No. 00
Job No. 00	Sheet No. 16

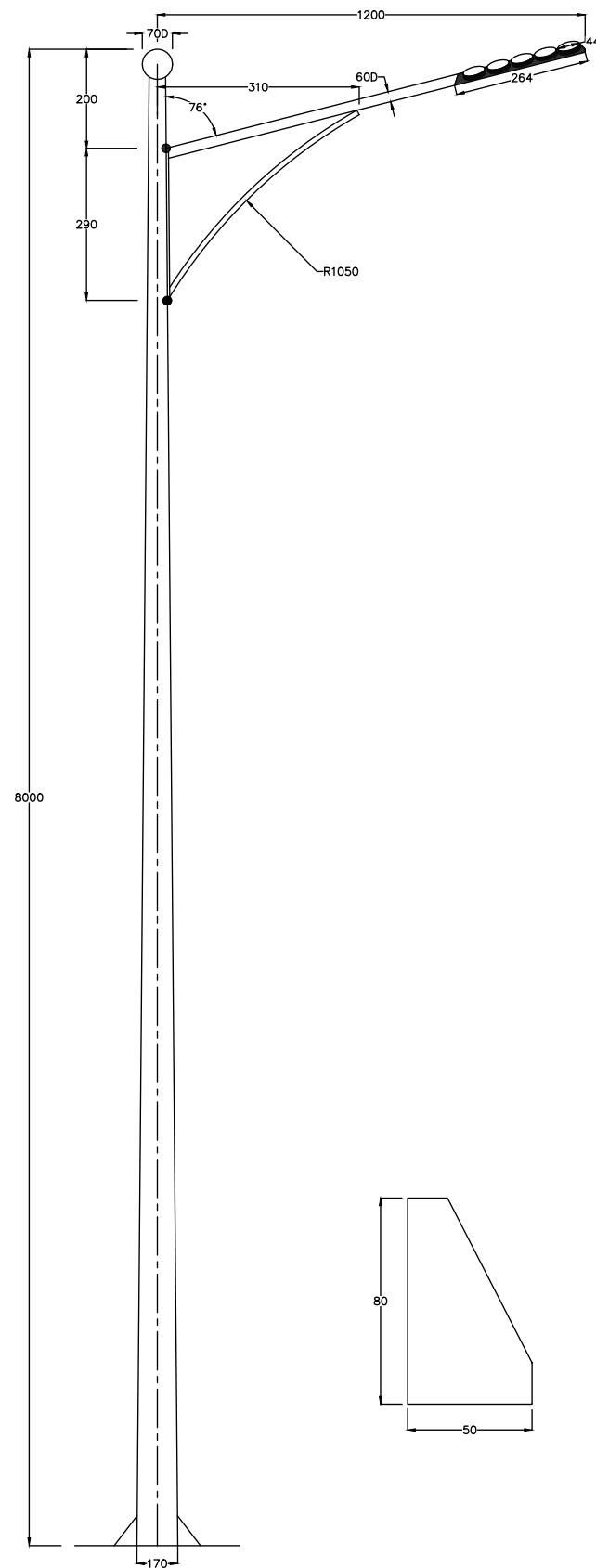

ALL MEASUREMENTS UNITS IN MM
UNLESS OTHERWISE STATED

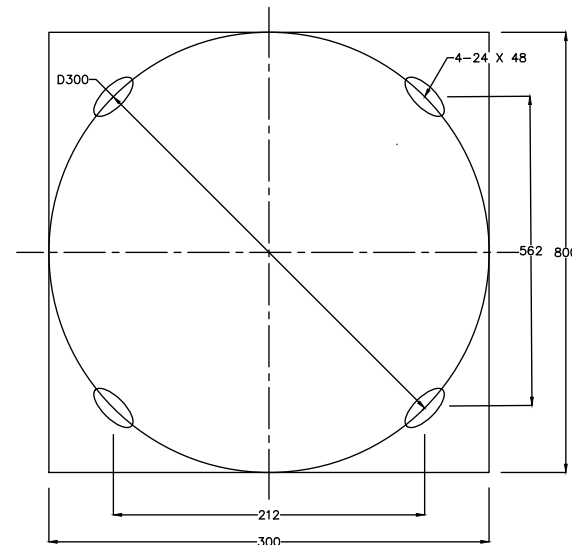
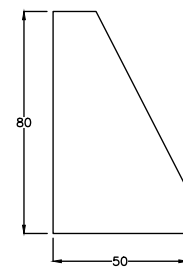

PLAN VIEW OF FOUNDATION

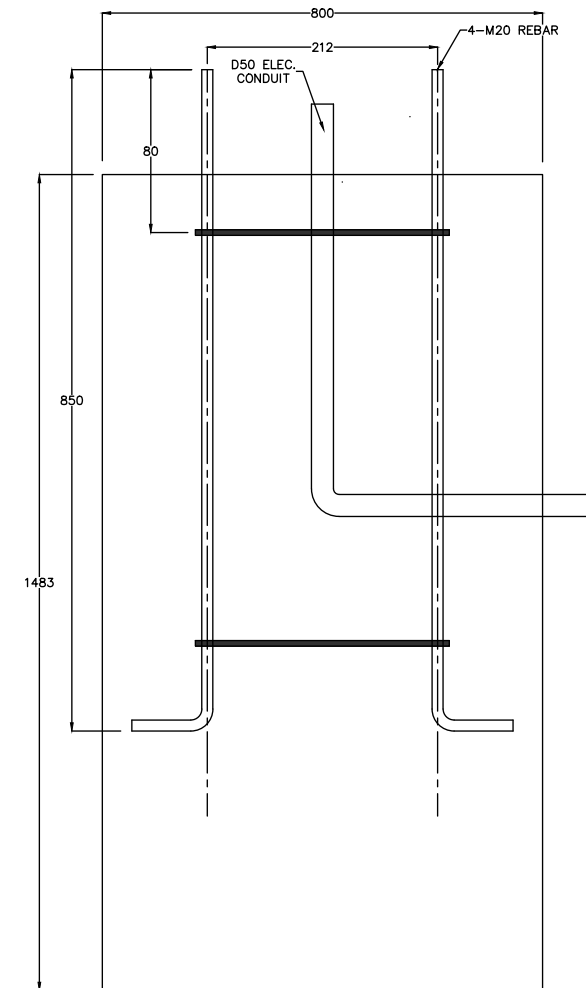

FOUNDATION DETAIL

Location	
SW Marine Dr. & West 16th Ave. University Endowment Lands	
Scale	
2024.04.10	0 FOR DETAILED REP SUB.
Project	
Redesign of Intersection: SW Marine Dr. & West 16th Ave.	
Client	
UBC SEEDS Sustainability Program	
Date	April 10, 2024
Drawn	Y. Wang
Design	Y. Wang
Checked	K. Miraki
Sheet Title	
Street Lighting	
Drawing No.	Revision No.
SP-17	00
Job No.	Sheet No.
00	17

ALL MEASUREMENTS UNITS IN MM
UNLESS OTHERWISE STATED

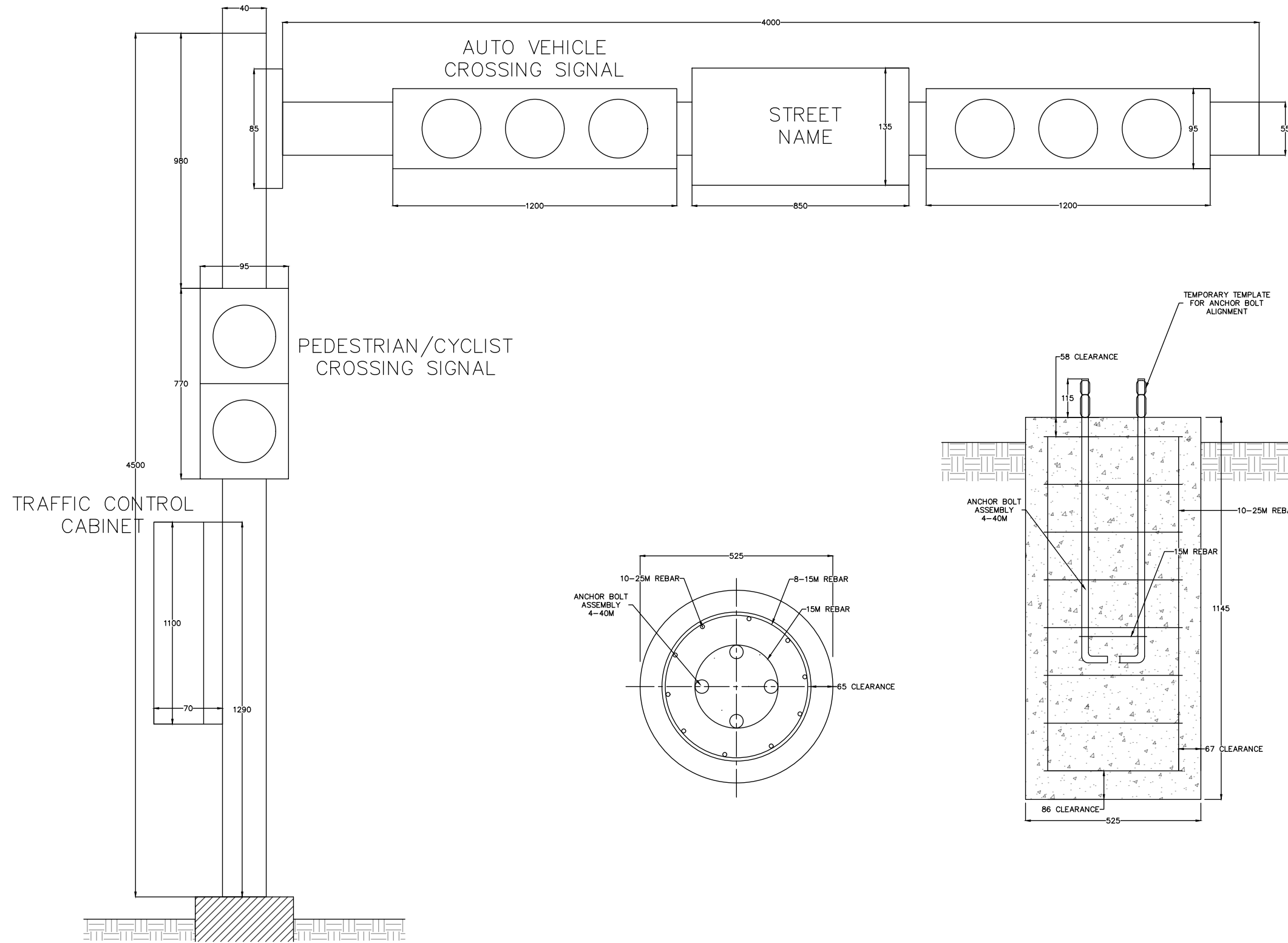

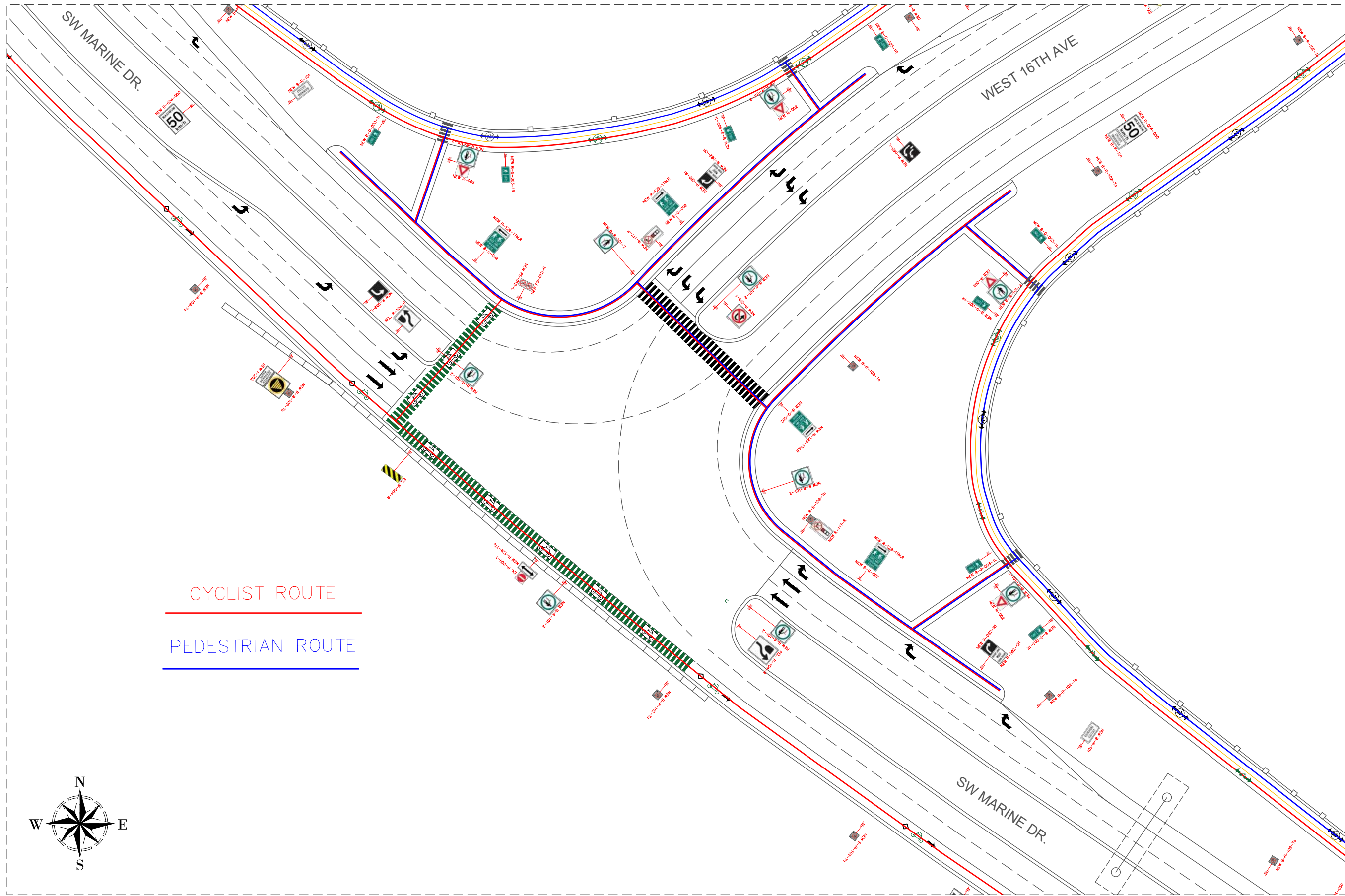

Location	
SW Marine Dr. & West 16th Ave. University Endowment Lands	
Scale	
0 200 400 MM	
2024.04.10	0 FOR DETAILED REP SUB.
Project	
Redesign of Intersection: SW Marine Dr. & West 16th Ave.	
Client	
UBC SEEDS Sustainability Program	
	
Date	April 10, 2024
Drawn	Y. Wang
Design	Y. Wang
Checked	K. Miraki
Sheet Title	
Traffic Signal Light	
Drawing No.	Revision No.
SP-18	00
Job No.	Sheet No.
00	18



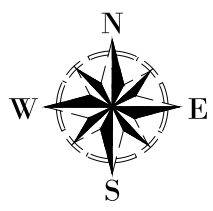

CYCLIST ROUTE

PEDESTRIAN ROUTE

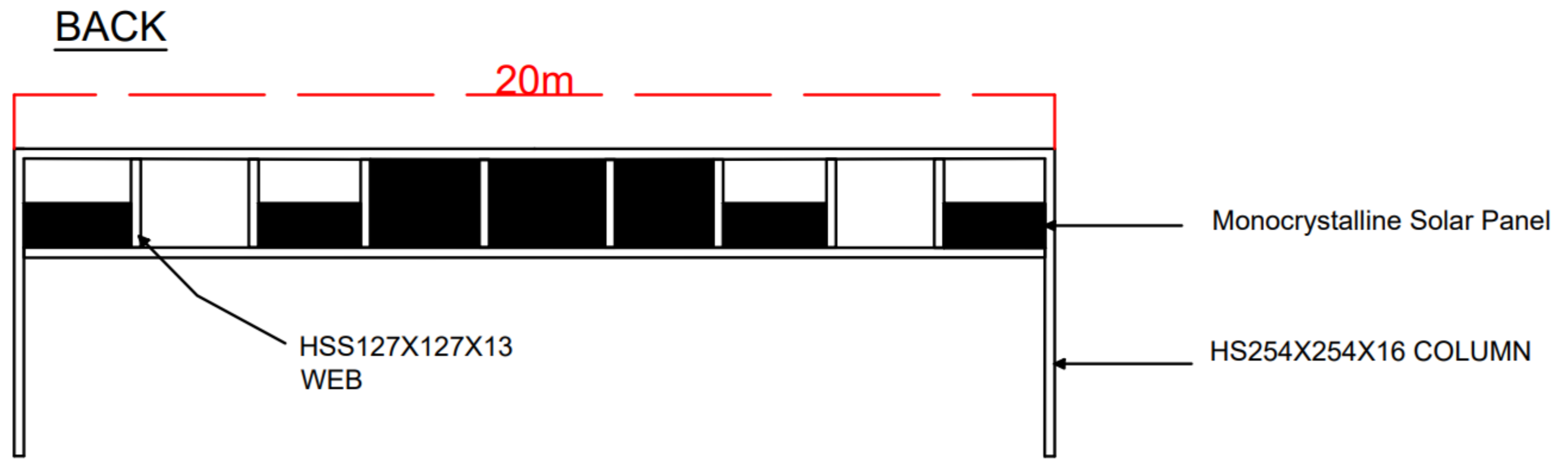
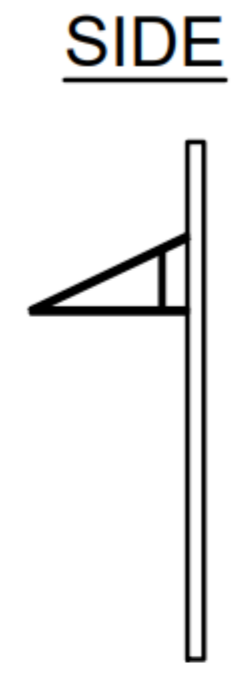
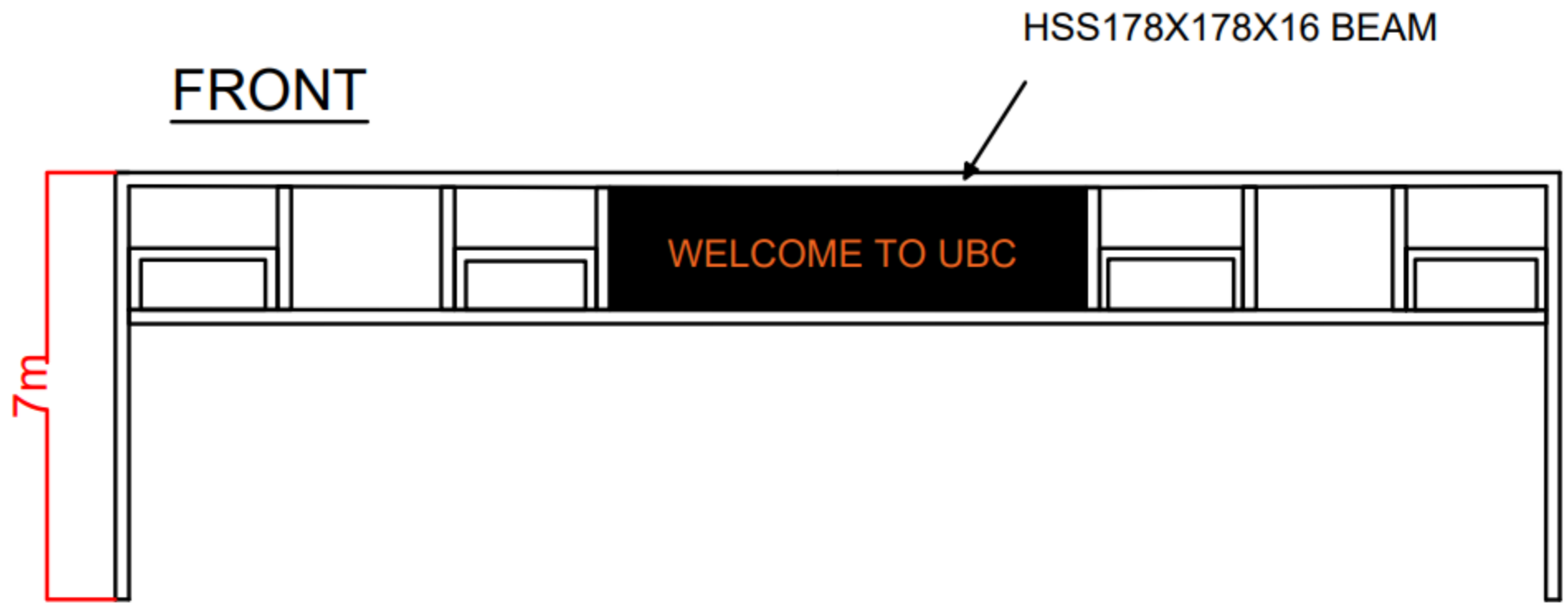

Location SW Marine Dr. & West 16th Ave. University Endowment Lands		
Scale 0 15 30 Meters		
DATE	REV	DESCRIPTION
2024.04.10	1	FOR FINAL REPORT SUB.
2023.12.12	0	FOR PRELIM REP SUB.
Project Redesign of Intersection: SW Marine Dr. & West 16th Ave.		
Client UBC SEEDS Sustainability Program		
		
Date	April 10, 2024	
Drawn	Y. Wang	
Design	Y. Wang	
Checked	K. Miraki	
Sheet Title Cyclist and Pedestrian Routes of the Intersection		
Drawing No.	SP-19	Revision No. 01
Job No.	01	Sheet No. 19



<u>Location</u> SW Marine Dr. & West 16th Ave. University Endowment Lands	
<u>Scale</u> 1:10	
<u>Project</u> Redesign of Intersection: SW Marine Dr. & West 16th Ave.	
<u>Client</u> UBC SEEDS Sustainability Program	
	
<u>Date</u> April 10, 2024	
<u>Drawn</u>	
<u>Design</u>	
<u>Checked</u>	
<u>Sheet Title</u> Gateway Design	
<u>Drawn No.</u>	<u>Revision No.</u>
<u>Job No.</u>	<u>Sheet No.</u>

FOUNDATION INFORMATION

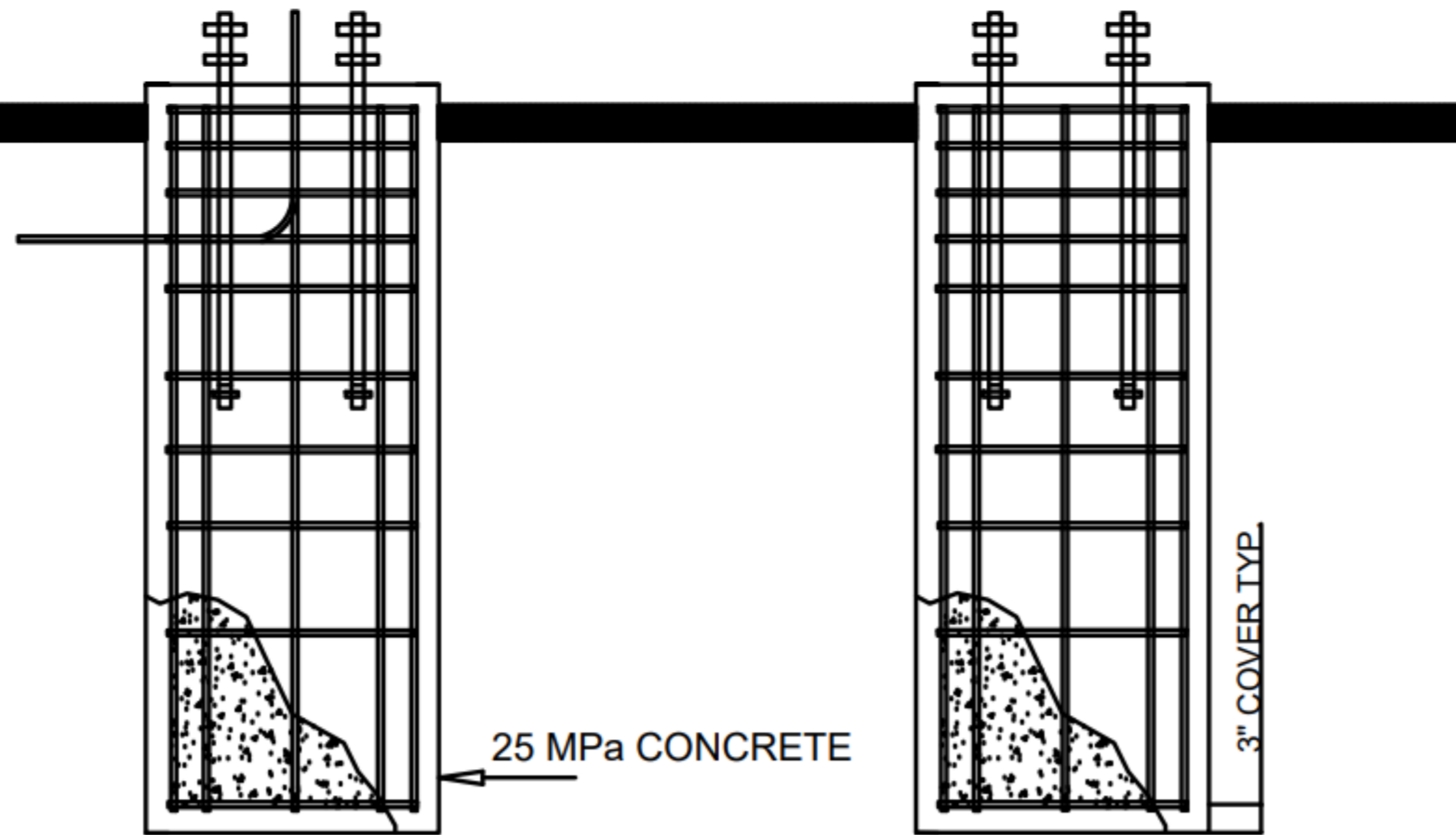
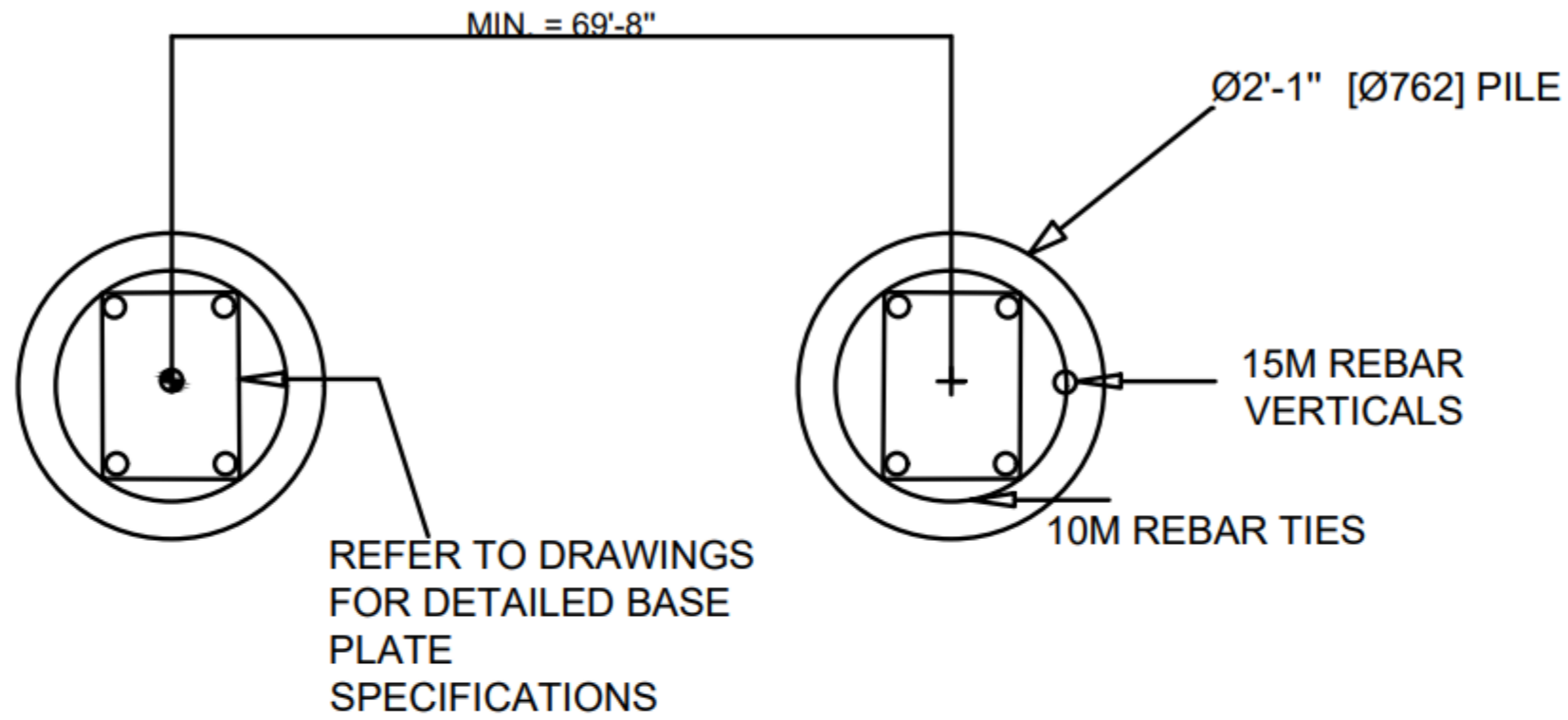

CONCRETE PILE FOUNDATION DETAIL

POST & BASE PLATE DETAILS

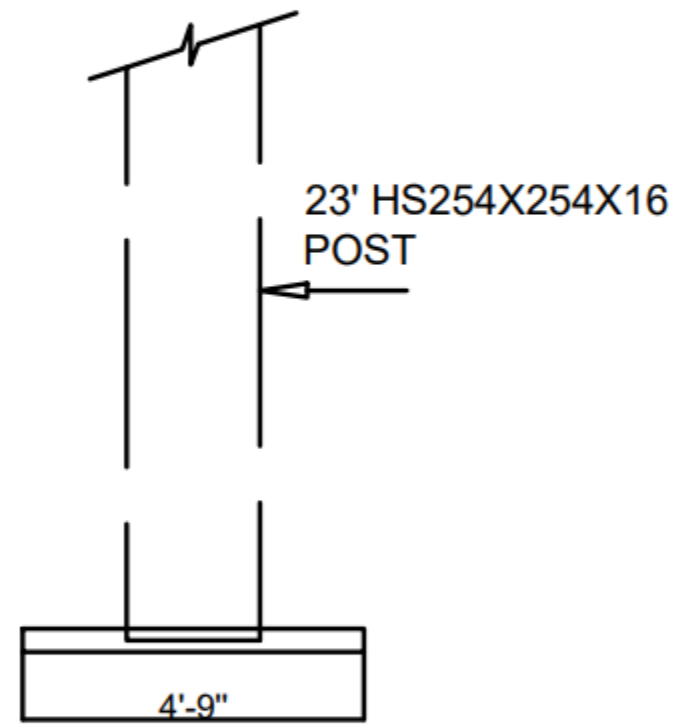

POST/BASE PLATE WELD DETAIL

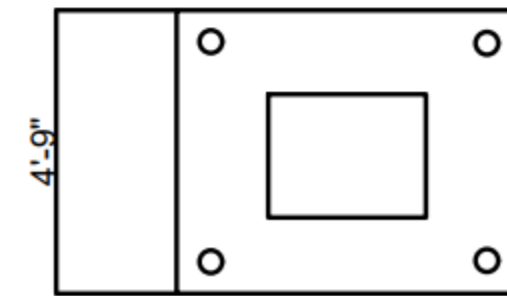

BASE PLATE DETAIL

Location:
SW Marine Dr. & West 16th Ave.
University Endowment Lands

Scale:
1:10

Project:
Redesign of
Intersection:
SW Marine Dr. & West
16th Ave.

Client:
UBC SEEDS Sustainability Program



Date:
April 10, 2024

Drawn:

Design:

Checked:

Sheet Title:

Footing Design
for Gateway

Drawing No.:

Revision No.:

Job No.:

Sheet No.:

Appendix G: Codes Used

Table 10: From the BC MOTI Supplement (F1)

Item#	Design Feature	Description of Specification	Pages(s)
1	Width for shoulder bikeway	Table 430.B: Minimum width is 1.5m	430-1
2	Turning radius of design vehicles	Table 720.A: Minimum corner radius of 14.5m for WB-20, turning speed 0-15km/h	720-2
3	Vehicle lane width	Table 430A: Minimum lane width (for rural highways, arterials, and low traffic volume roads) is 3.6m	430-1
4	Paved shoulder width	Table 430A: Minimum paved shoulder width ranges from 1.0 to 3.0m, depending on road class	430-1

Table 11: From the BC Active Transportation Design Guide (F2)

Item#	Design Feature	Description of Specification	Pages(s)
1	Width for shoulder bikeway	Table D-19: Desired width of 1.7m if speeds are 50km/h or less	D82
2	Full width of multi-use pathway	Table E-20: Desired width of 4.0m in context of arterial or collector roads	E15
3	Design speed of multi-use pathway	For most off-street pathways, the minimum design speed is 20 km/h	E18
4	Longitudinal grade of multi-use pathway	The recommended max longitudinal grade is 5%	E19
5	Required signage for multi-use pathway	For separated pathways, the Pathway Organization Sign MUTCDC RB-94 is used	E31

Table 12: From TAC's Manual of Uniform Traffic Control Devices for Canada (F3)

Item#	Design Feature	Description of Specification	Pages(s)
1	Width of crosswalk pavement marking	The minimum width is 2.5m	A6.3

Table 13: From AASHTO's Policy on Geometric Design (F4)

Item#	Design Feature	Description of Specification	Pages(s)
1	Lane change and deceleration distance for the design speed	Table 9-20: The minimum lane change and deceleration distance is 50m	9-96
2	Taper ratio for auxiliary lanes	"The taper rate may be 8:1 [L:T] for design speeds up to 30mph (50 km/h)"	9-101

Appendix H: Gateway Lift Plan

<p>Task 1: Pre-Lift Preparation</p>	<p>1.1 Conduct site assessment to identify any potential hazards, ie. Overhead utilities.</p> <p>1.2 Inspect all lifting equipment including cranes, hoists, slings, and rigging gear. Ensure they are in good working condition.</p>
<p>Task 2: Crane Mobilization and Setup</p>	<p>2.1 Select appropriate crane for the size and weight of gateway segment being lifted</p> <p>2.2 Set crane at a safe distance from gateway location.</p> <p>2.3 Verify ground conditions and place necessary padding to support the crane.</p> <p>2.4 Determine rigging configuration and ensure high quality slings are evenly distributed across the load.</p>
<p>Task 3: Gateway Installation</p>	<p>3.1 Coordinate with the installation team to position the gateway components adjacent to the installation site.</p> <p>3.2 Attach lifting gear to gateway and communicate with crane operator and lifting team to ensure segments are aligned.</p> <p>3.3 Install gateway to preinstalled components</p>
<p>Task 4: Post-Lift Testing</p>	<p>4.1 Ensure the structural integrity of the installed gateway</p> <p>4.2 Ensure the display system functions correctly</p> <p>4.3. Coordinate with traffic control to undo the lane closure.</p>